

INSTRUCTION MANUAL  
RETINAL CAMERA

---

# TRC-50DX



# INTRODUCTION

Thank you for purchasing the TOPCON TRC-50DX Retinal Camera.

This instrument is used to observe, take pictures or record pictures of the posterior segment of the eye through the pupil.

In Type IA of this instrument, the fluorescein angiography with indocyanine green is possible.

This instrument has the following features:

- This instrument assists the user in obtaining pictures of exceptional and stable quality.
- The instrument is easier to use and operate than previous models.
- A wide variety of optional accessories are available for diverse photographic and imaging purposes.

This manual outlines the TRC-50DX Retinal Camera, including operating procedures, troubleshooting, maintenance and cleaning.

Before using the instrument, carefully read the "DISPLAY FOR SAFE USE" and the "SAFETY CAUTIONS" to familiarize yourself with the features of the TRC-50DX Retinal Camera and to ensure that you operate it in an efficient and safe manner.

Always keep this Instruction Manual at hand.

## [Warning]

Be careful not to bump the patient's eyes or nose with the instrument during operation.

[The patient may be injured.]



This symbol is applicable for EU member countries only. To avoid potential negative consequences for the environment and possibly human health, this instrument should be disposed of (i) for EU member countries - in accordance with WEEE (Directive on Waste Electrical and Electronic Equipment), or (ii) for all other countries, in accordance with local disposal and recycling laws.

## CAUTIONS FOR USE

### Basic caution

When taking a picture, make sure that the patient keeps his/her hands away from the movable parts to avoid possible injury.

### Disposal

When disposing of TRC-50DX parts, follow the local regulations for disposal and recycling.

"Because prolonged intense light exposure can damage the retina, the use of the device for ocular examination should not be unnecessarily prolonged, and the brightness setting should not exceed what is needed to provide clear visualization of the target structures. This device should be used with filters that eliminate UV radiation (<400nm) and, whenever possible, filters that eliminate short-wavelength blue light (<420nm).

The retinal exposure dose for a photochemical hazard is a product of the radiance and the exposure time. If the value of radiance were reduced in half, twice the time would be needed to reach the maximum exposure limit.

While no acute optical radiation hazards have been identified for fundus cameras, it is recommended that the intensity of light directed into the patient's eye be limited to the minimum level which is necessary for diagnosis. Infants, aphakes and persons with diseased eyes will be at greater risk. The risk may also be increased if the person being examined has had any exposure with the same instrument or any other ophthalmic instrument using a visible light source during the previous 24 hours. This will apply particularly if the eye has been exposed to retinal photography."

"Caution: Federal laws restricts this device to the sale by or on the order of a physician."

## **ENVIRONMENTAL CONDITIONS FOR USE**

Temperature: 10°C ~ 40°C  
Humidity: 30% ~ 75% (Non-condensing)  
Air pressure: 700hPa ~ 1060hPa

## **STORAGE, USAGE PERIOD AND OTHERS**

1. Environmental conditions (without package)  
Temperature: 10°C ~ 40°C  
Humidity: 30% ~ 75% (Non-condensing)  
Air pressure: 700hPa ~ 1060hPa
2. When storing the instrument, ensure that the following conditions are met:
  - (1) The instrument must not be splashed with water.
  - (2) Store the instrument away from environments where air pressure, temperature, humidity, ventilation, sunlight, dust, salty/sulfurous air, etc. could cause damage.
  - (3) Do not store or transport the instrument on a slanted or uneven surface or in an area where it is subject to vibrations or instability.
  - (4) Do not store the instrument where chemicals are stored or gas is generated.
3. Normal life span of the instrument:  
8 years from delivery providing regular maintenance is performed [TOPCON data]

## **ENVIRONMENTAL CONDITIONS FOR PACKAGING IN TRANSPORTATION**

Temperature: -20°C ~ 50°C  
Humidity: 10% ~ 95%

## **CHECKPOINTS FOR MAINTENANCE**



1. Periodically inspect the instrument and its parts.
2. Before using the instrument after a long period of inactivity, make sure that it operates safely and normally.
3. Be careful not to stain the objective lens with fingerprints, dirt, etc., as this will affect the coatings and quality of pictures that the instrument takes.
4. When the instrument is not in use, cap the objective lens and cover the instrument with the dust cover.
5. If the objective lens is stained, clean it according to "CLEANING THE OBJECTIVE LENS" on page 58 of this manual.

# DISPLAY FOR SAFE USE







To encourage safe and proper use and to prevent injuries to the operator and others or potential damage to property, important messages are put on the instrument body and inserted in the instruction manual.

We suggest that everyone understand the meaning of the following displays, icons and text before reading the "SAFETY CAUTIONS" and observe all listed instructions.

## DISPLAYS











Display	Meaning
 <b>WARNING</b>	Incorrect handling by ignoring this display may lead to a risk of death or serious injury.
 <b>CAUTION</b>	Incorrect handling by ignoring this display may lead to personal injury or physical damage.
	<ul style="list-style-type: none"><li>• Injury refers to cuts, bruises, burns, electric shock, etc. which do not require hospitalization or extended medical treatment.</li><li>• Physical damage refers to extensive damage to the building, nearby equipment and/or surrounding furniture.</li></ul>

## ICONS











Icon	Meaning
	Prohibition. Specific content is expressed with words or a picture near the icon. 
	Mandatory Action Specific content is expressed with words or a picture near the icon. 
	Caution Specific content is expressed with words or a picture near the icon. 

# SAFETY CAUTIONS









## WARNINGS

Icon	Prevention item	Page
	To avoid fire and electric shock in case of leakage, be sure to use a grounded receptacle. Do not connect to receptacles that are not grounded.	20
	To avoid electric shock, do not attempt disassembling, rebuilding and/or repairs on your own. Ask your dealer for repairs.	46
	Do not remove the external covers from the main unit, chinrest unit or power supply unit except for the lamp house cover. You may receive an electric shock.	46
	To avoid electric shock when replacing the fuse, be sure to unplug the instrument before removing the fuse cover. Do not use ungrounded outlets. Do not plug in the instrument without the fuse cover.	57
	To avoid fire in the event of an instrument malfunction, use only the fuses that are marked with the label at the side of the fuse holder.	57
	To avoid fire and electric shock, install the instrument in a dry place free of water and other liquids.	—
	To avoid fire and electric shock, do not put cups or other containers with liquids near the instrument.	37, 39, 40
	To avoid electric shock, do not insert metal objects into any vents and/or slots.	—
	Disconnect the power plug from the outlet before removing the lamp house cover. Electric shock may occur if you remove the lamp house cover without disconnecting the power plug. Do not connect the power plug to the outlet while the lamp house cover is not set on the instrument.	—
	To avoid fire in the event of an instrument malfunction, immediately turn OFF the power switch and unplug the cable if you see smoke coming from the instrument, etc. Ask your dealer for repairs.	—
	To avoid injury, remove the accessories of the UPPER mount before carrying the instrument. The instrument may tip over.	62

## ⚠ CAUTIONS

Icon	Prevention item	Page
	To prevent damage and injuries, do not install the instrument on an uneven, unsteady or sloped surface.	53
	To avoid electric shock, do not handle the plugs with wet fingers.	20
	To avoid discomfort or damage to the patient's eye, do not brighten the illumination lamp more than necessary.	32
	To avoid discomfort or damage to the patient's eye, do not make a flash intensity level higher than necessary.	32
	To avoid injury while inclining the instrument body, do not place your fingers into the gap between the instrument body and the 1st arm.	32
	To avoid injury while moving the instrument body, do not place your fingers into the gap between the 1st/2nd arm and the chinrest column. *Please give proper instructions to the patient.	32
	To avoid burns, do not replace the lamp with a new one immediately after it goes off. Allow time for it to cool.	54
	To avoid electric shock, do not replace the xenon lamp with a new one immediately after it goes off.	55
	To avoid injury while moving the base, do not place your fingers into the gap between the instrument base and the power supply unit.	32
	Pay attention to the clearance between the objective lens and the patient. When the main body is moved, the objective lens may bump against the patient's eye or nose inflicting a minor injury.	32

## CAUTIONS

Icon	Prevention item	Page
	To prevent falls and injury during transportation of the instrument, be sure to lock the base and arm by using the locking levers. This will prevent the instrument from moving and sliding.	—
	To avoid injury during carrying, be sure to hold the instrument body at the bottom with two people. Carrying by one person may cause backache or injury by falling. Holding at areas other than the bottom may also cause pinched fingers and injury, as well as falling, thereby causing damage to the instrument.	—
	To avoid falling and injury while moving the instrument on a rolling table, be sure to use an approved instrument table.	—
	To avoid injury while moving the chinrest up and down, instruct the patient to keep hands away from moving parts.	30
	Be careful not to let the patient hold the column. His/her finger may be pinched between the column and 1st/2nd arm causing injury.	30
	To avoid electric shock, be sure to turn the power switch off and unplug the power cord before replacing the lamp.	54, 55
	Ensure that the 35mm camera is installed firmly by fastening the 35mm camera body locking lever. If installed loosely, the camera may fall off, resulting in severe damage to the unit and bodily injury.	62
	When installing accessories, secure them firmly by fastening the accessory locking lever. If installed loosely, the accessories may fall off, leading to bodily injury.	62
	This instrument has been tested (with 100-120V/200-240V) and found to comply with IEC60601-1-2: 2001. This instrument radiates radio frequency energy within standards and may affect other devices in the vicinity. If you have discovered that turning on/off the instrument affects other devices, we recommend that you change its position, keep a proper distance from other devices, or plug it into a different outlet. Please consult your authorized dealer if you have any additional questions.	—



# USAGE AND MAINTENANCE

## USAGE

- The TRC-50DX Retinal Camera is an electric instrument for medical use. Use this instrument under a doctor's guidance.

## USER MAINTENANCE

To ensure the safety and performance of the instrument, all maintenance work, unless specified in this manual, shall be conducted by trained service engineers. The following maintenance tasks may be done by the user. For details, see the relevant part of this manual.

### **Replacing lamps:**

The illumination lamp and Xenon lamp may be replaced by the user. For details, see "REPLACING THE ILLUMINATION LAMP" on page 54 and "REPLACING THE XENON LAMP" on page 55.

### **Replacing fuses:**

The fuses on the instrument body may be replaced by the user. For details, see "REPLACING THE FUSE" on page 57.

### **Cleaning the objective lens:**

The objective lens may be cleaned by the user. For details, see "CLEANING THE OBJECTIVE LENS" on page 60.

## ESCAPE CLAUSES

- TOPCON shall not take any responsibility for damage due to fire, earthquakes, actions by third persons and other accidents, or damage due to negligence and misuse by the user and any use under unusual conditions.
- TOPCON shall not take any responsibility for damage derived from inability to properly use this instrument, such as loss of business profit and suspension of business.
- TOPCON shall not take any responsibility for damage caused from using this instrument in a manner other than that described in this Instruction Manual.
- Diagnoses made shall be the responsibility of pertaining doctors and TOPCON shall not take any responsibility for the results of such diagnoses.

# WARNING DISPLAYS AND POSITIONS

To ensure safety, this machine provides warning displays.

Use the instrument correctly by observing the display instructions. If any of the following display labels are missing, contact your TOPCON dealer at the address listed on the back cover of this manual.

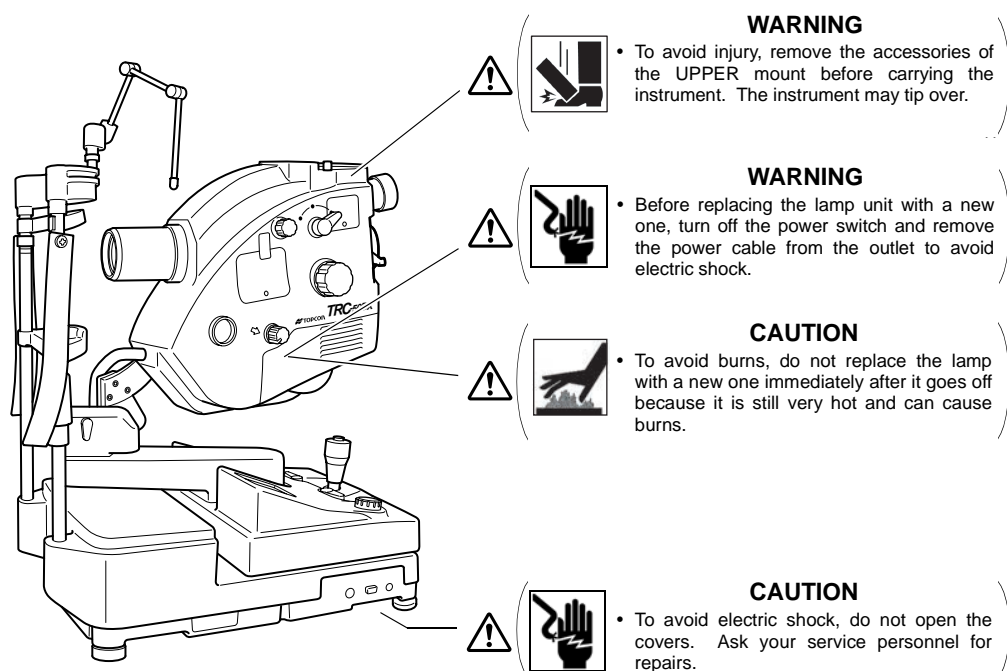
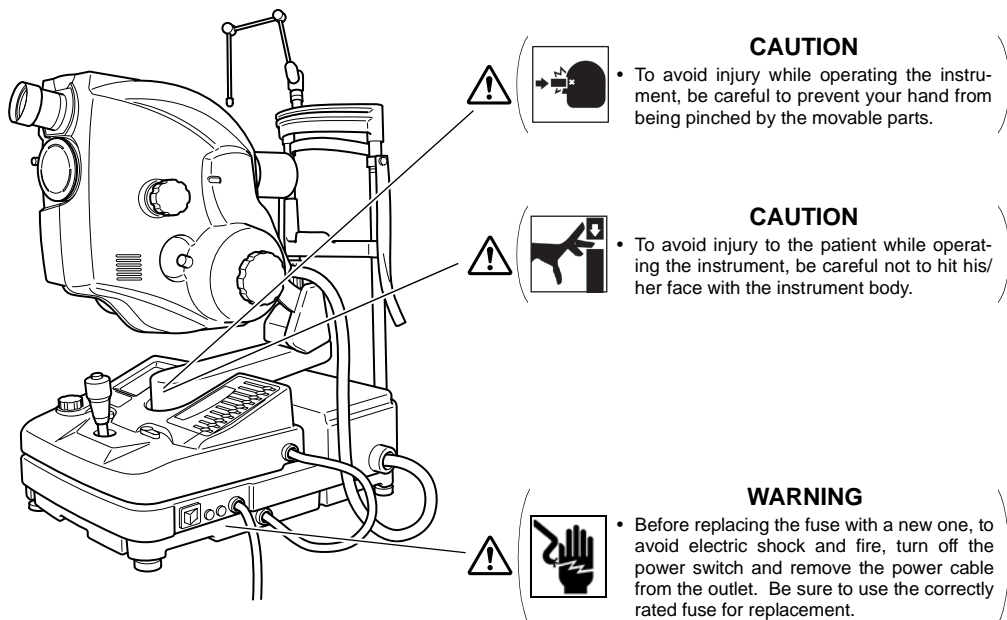

# CONTENTS

INTRODUCTION .....	1
CAUTIONS FOR USE .....	1
ENVIRONMENTAL CONDITIONS FOR USE.....	2
STORAGE, USAGE PERIOD AND OTHERS.....	2
ENVIRONMENTAL CONDITIONS FOR PACKAGING IN TRANSPORTATION.....	2
CHECKPOINTS FOR MAINTENANCE .....	2
DISPLAY FOR SAFE USE.....	3
SAFETY CAUTIONS .....	4
USAGE AND MAINTENANCE.....	7
USAGE .....	7
USER MAINTENANCE.....	7
ESCAPE CLAUSES.....	7
WARNING DISPLAYS AND POSITIONS .....	8

## NOMENCLATURE

COMPONENTS OF MAIN UNIT.....	12
COMPOSITION OF PARTS WHICH CONTACT WITH THE HUMAN BODY.....	14
COMPONENTS OF BASE UNIT .....	15
COMPONENTS ON CONTROL PANEL SCREEN.....	16
NAMES IN OPTICAL FINDER .....	18
STANDARD ACCESSORIES .....	19

## SETUP

CONNECTING THE POWER CORD .....	20
CONNECTING THE EXTERNAL DEVICE .....	21
RESET FROM POWER SAVE STATE .....	22
SETTING ON THE SET MENU DISPLAY .....	23

## BASIC OPERATIONS

PREPARATION FOR PHOTOGRAPHY .....	28
PREPARATION OF THE PATIENT .....	30
COLOR PHOTOGRAPHY .....	32
FAG PHOTOGRAPHY .....	37
ICG FLUORESCIN PHOTOGRAPHY (ONLY IN TYPE IA).....	39
RED FREE PHOTOGRAPHY WITH GREEN FILTER (ONLY IN RELEVANT PRODUCTS).....	40
AUTO FLUO (AUTO FLUORESCENCE) PHOTOGRAPHY (ONLY IN RELEVANT PRODUCTS).....	40

## OBJECTIVE OPERATIONS

PHOTOGRAPHY BY INCLINATION AND SWINGING.....	42
BLUE FILTER PHOTOGRAPHY.....	43
PHOTOGRAPHY WITH ALTERNATIVE FILTER (EXCLUDING TYPE IA).....	43
STEREO PHOTOGRAPHY .....	44
INTERNAL FIXATION TARGET MOUNT (ONLY IN TYPE IA) .....	45

## BEFORE REQUESTING SERVICE

TROUBLESHOOTING.....	46
ERROR CODE LIST .....	49

## SPECIFICATIONS AND PERFORMANCE

SPECIFICATIONS .....	50
ELECTRIC RATING.....	50
SYSTEM CLASSIFICATION.....	51
DIMENSIONS AND WEIGHT .....	51
PURPOSE OF USE .....	51
OPERATION PRINCIPLE .....	52

## MAINTENANCE

DAILY CHECKUPS.....	53
ORDERING CONSUMABLES .....	53
MAINTENANCE BY THE DEALER .....	53
REPLACING THE ILLUMINATION LAMP .....	54
REPLACING THE XENON LAMP .....	55
REPLACING THE FUSE .....	57
REFILLING THE CHINREST TISSUE PAPER.....	58
THE FAG FLUORESCENCE FILTER.....	58

## CLEANING

CLEANING THE EXTERNAL COVER, CONTROL PANEL AND OTHERS.....	60
CLEANING THE PARTS WHICH COME INTO CONTACT WITH THE PATIENT .....	60
CLEANING THE OBJECTIVE LENS .....	60
CLEANING THE LENS WHICH IS SEEN IN UPPER MOUNT .....	61

## OPTIONAL ACCESSORIES

OPTIONAL ACCESSORY MOUNTING/DETACHING METHODS.....	63
ACCESSORY LENS CLEANING METHODS.....	67
1x RELAY LENS ADAPTER OR-2 .....	68
TV RELAY LENS ADAPTER.....	69

## REFERENCE MATERIAL

SHAPE OF PLUG .....	71
SYMBOL .....	71
USABLE AUTOMATIC INSTRUMENT TABLE .....	72
ELECTROMAGNETIC COMPATIBILITY .....	73
RELATION BETWEEN SETTING OF ILLUMINATION/FLASH LEVEL AND MAXIMUM RADIANCE.....	77
INFORMATION ABOUT THE OPTICAL RADIATION HAZARD FOR THE USER .....	78

# NOMENCLATURE

## COMPONENTS OF MAIN UNIT

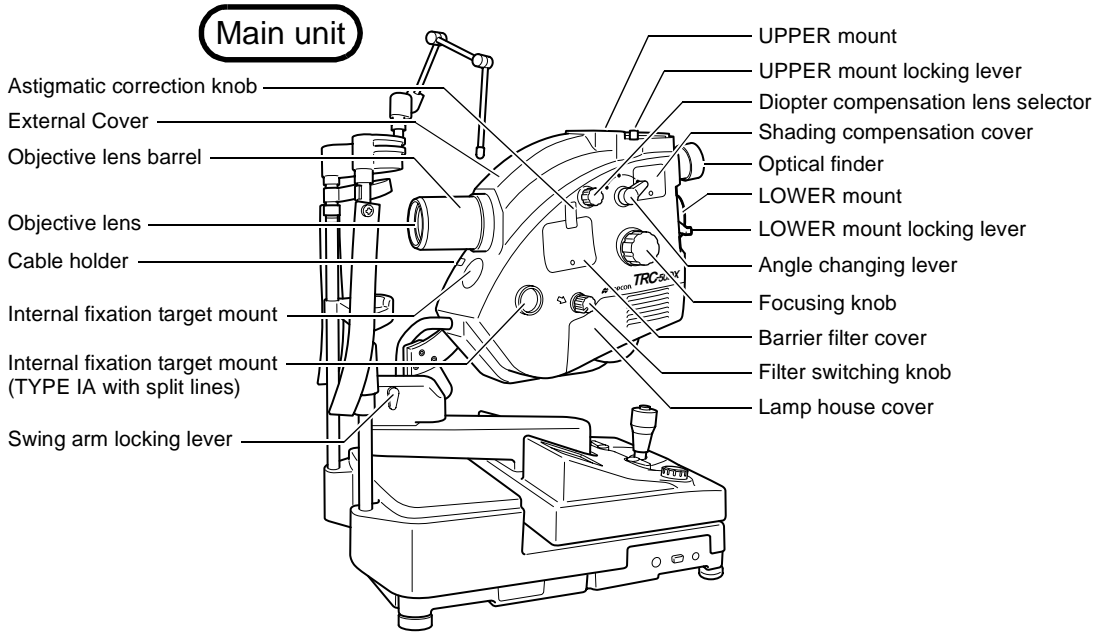

- Angle changing lever..... 50°, 35° or 20° may be selected as the angle of coverage.
- Diopter compensation lens selector ..... Used to compensate the dioptric power of strong myopia and hyperopia in the patient and also used for ocular anterior photography.
- Filter switching knob..... Changed for different kinds of photography.
- UPPER mount..... Optional accessories (different types of relay lenses) are mounted here.
- Internal fixation target mount..... Usable when the split lines are OFF. (Only in Type IA with split lines)
- Shading compensation cover..... Open this cover when cleaning the lens which is seen in the UPPER mount.
- Astigmatic correction knob ..... Used when correcting the astigmatism degree of the patient. (Only in relevant products)
- Internal fixation target mount..... The internal fixation target can be mounted. (This can be installed as an optional accessory in Type IA (without split lines), and as a standard accessory in Type IA (with split lines).)

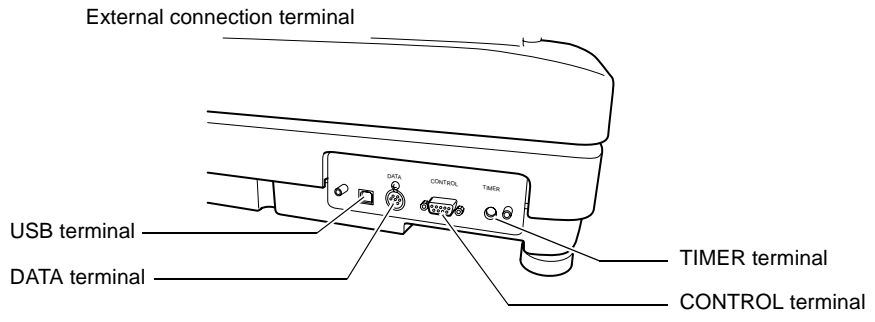
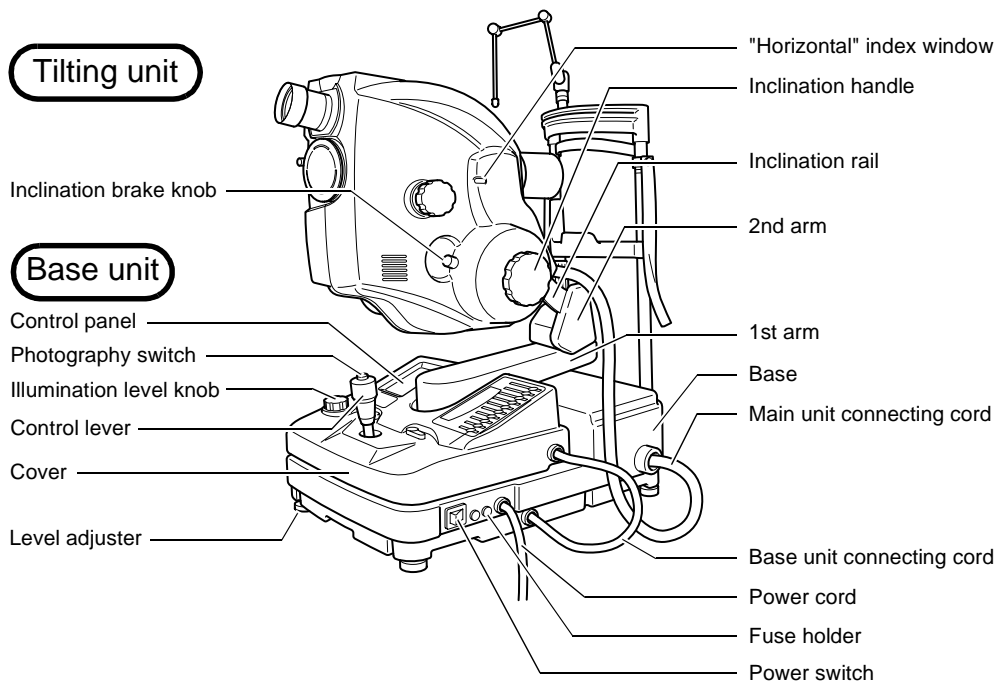

- Photography switch..... Press this switch, and the xenon lamp flashes and different types of photography are possible.
- Inclination handle ..... Performs inclination in upper 15° and lower 10°.
- Inclination brake knob ..... Inclination is set to "free" or "lock" by turning this knob.
- 2nd arm ..... Swings up to 30° to the right and left.
- CONTROL terminal ..... Used to connect to IMAGENet.
- DATA terminal ..... Used to communicate with IMAGENet.
- TIMER terminal ..... Used to connect with the video timer.
- USB terminal ..... Used to connect to IMAGENet.

**Chinrest unit**

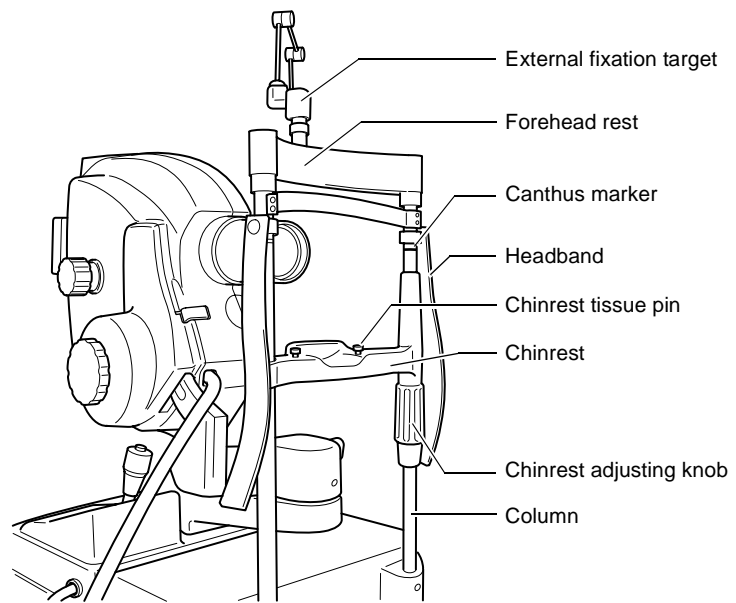

Headband.....Used when fixing the patient's head. (Only in relevant products)

**COMPOSITION OF PARTS WHICH CONTACT THE HUMAN BODY**

- Forehead rest : Polyamide resin
- Chinrest : Polyamide resin
- Headband : Polyvinyl chloride resin
- Chinrest adjusting knob : Polyacetal resin
- Chinrest tissue pin : Polyamide resin
- Chinrest tissue : Paper



## COMPONENTS OF BASE UNIT

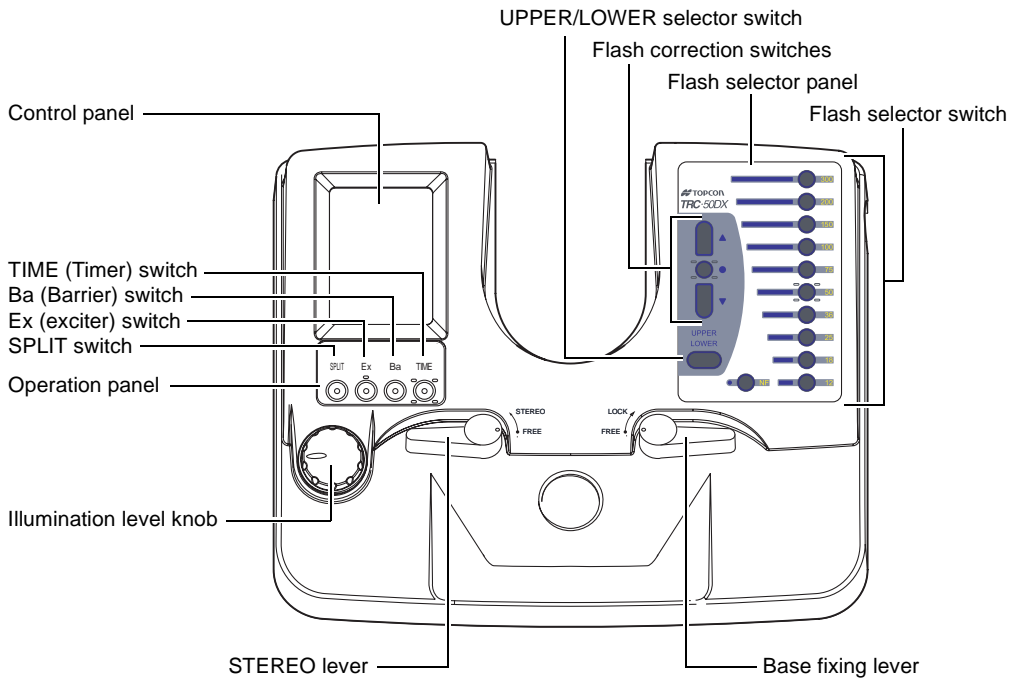

- Control panel..... On this touch panel, the set data are displayed and a variety of setting is done.
- Illumination level knob..... Adjusts the illumination level according to the patient's eye.
- Ba (Barrier) switch..... Sets the barrier filter. Press this switch again, and the barrier filter is removed.
- TIME (Timer) switch ..... Press this switch, and the timer starts. Press it again, and the timer stops.
- Ex (exciter) switch ..... Sets the exciter filter. Press this switch again, and the exciter filter is removed.
- SPLIT switch ..... Sets the internal fixation target to "OFF". Press this switch, and the split lines are set. Press this switch again, and the split lines are removed. (Only in relevant products)
- STEREO lever..... Used for stereo photography. Refer to "STEREO PHOTOGRAPHY" on page 44 for details.
- Base fixing lever..... Used to lock the base.
- UPPER/LOWER selector switch.... When UPPER is selected, photography by the UPPER set camera is possible.  
When in POWER SAVE mode, push this switch to reset the instrument.
- Flash selector switch..... Photography light intensity can be selected in 11 steps. NF means no light emission from the xenon flash lamp.
- Flash correction switches..... Increase or decrease the preset light intensity. (It can be changed by 21 steps.) Press the  $\triangle$  button to increase it or the  $\nabla$  button to decrease it. For example, when the preset light quantity is 36W-s, one press of the  $\triangle$  button changes the setting to a value between 36W-s and 50W-s and turns on both switches (36) and (50).

## COMPONENTS ON CONTROL PANEL SCREEN

### Setting operation display (Example of the photography mode color)

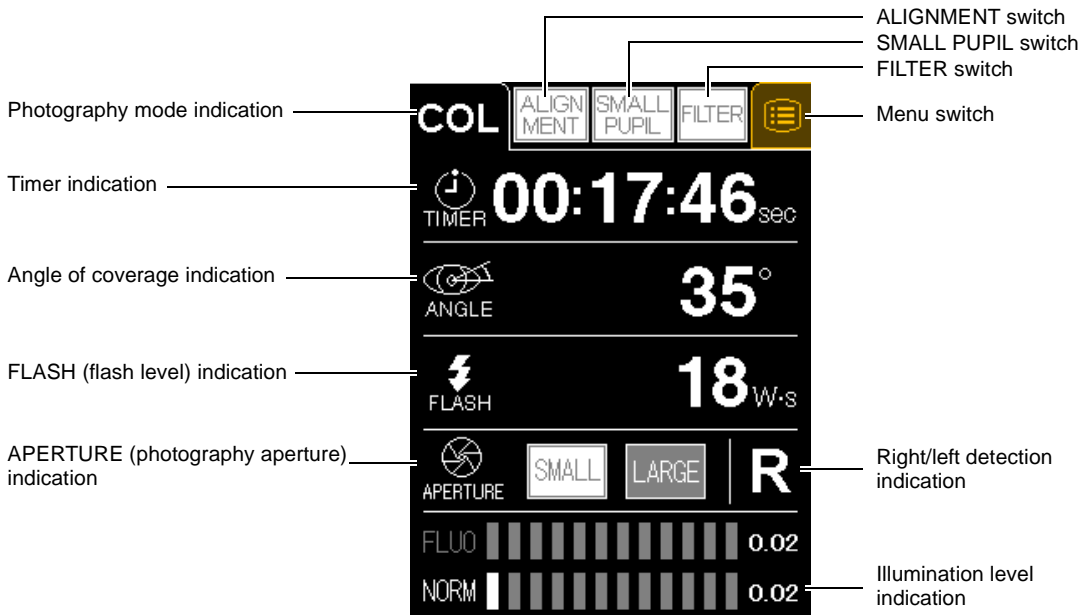

Photography mode indication ... Indicates the currently set photography mode. The modes, "COL (Color)", "GRE (Green)", "FA (FAG)", "F1, F2, AF (AUTO FLUO)" and "IA (ICG fluorescein)" ("AF, IA" in use only in Type IA) are changed by operating "Filter switching knob" on the main unit, "Ex switch" and "Ba switch".

ALIGNMENT switch ..... Turns on/off the alignment bright spot.

SMALL PUPIL switch ..... Changes the current mode to the microcoria mode.

FILTER switch ..... Ba (barrier) filter or Ex (exciter) filter is set in the link operation with the photography switch. When the link operation is OFF, it is possible to take a picture as regarding the Ex (exciter) filter as the blue filter.

Menu switch ..... Indicates the set menu. While the TIME switch is operating, this switch disappears on the screen to prevent a wrong operation.

Timer indication ..... Press the TIME (timer) switch on the base unit, and the timer starts. Press the switch again, and the timer stops.

Angle of coverage indication ..... Indicates the angle of coverage, which is set by the angle changing lever on the main unit.

FLASH (flash level) indication ... Indicates the FLASH (flash level), which is set by the flash selector switch and the flash correction switches on the base unit.

APERTURE ..... By using the **SMALL** switch, it is possible to adjust the focus easily (increased depth of field). By using the **LARGE** switch, it is possible to take a picture with low flash level. This can be used in color photography and ICG fluorescein photography (only in Type IA).

Right/left detection indication .... "L" (left eye) or "R" (right eye) is indicated.

Illumination level indication ..... Indicates the illumination level (halogen), which is set by the illumination level knob on the base unit.

## SET MENU display

Carries out a variety of settings. Press the MENU button (☰) on the setting operation display, and "SET MENU" will be displayed. Refer to "SETTING ON THE SET MENU DISPLAY" on page 23.

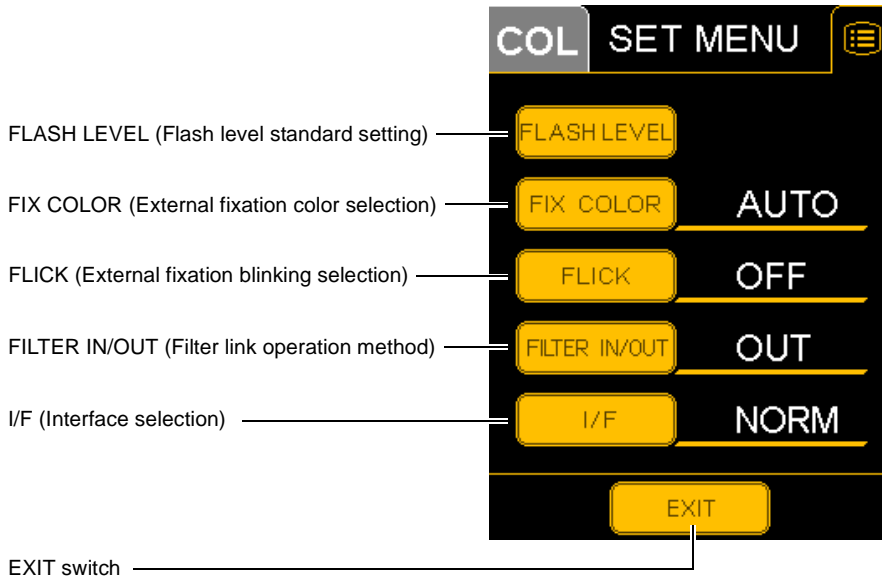

- FLASH LEVEL (Flash level standard setting) .... Sets the flash intensity level standard value for each photography mode.
- FIX COLOR (External fixation color selection)... Selects the color of the external fixation lamp, "AUTO" (automatic), "GREEN" or "RED".
- FLICK (External fixation blinking selection)..... Selects the status of the external fixation lamp, "ON" (blinking) or "OFF" (lighting)
- FILTER IN/OUT (Filter link operation method) ... Selects the link operation method for the photography switch and Ba (barrier) filter.
- I/F (Interface) switch..... Changes the interface.
- EXIT switch ..... Returns to the setting operation display.

**NAMES IN OPTICAL FINDER**

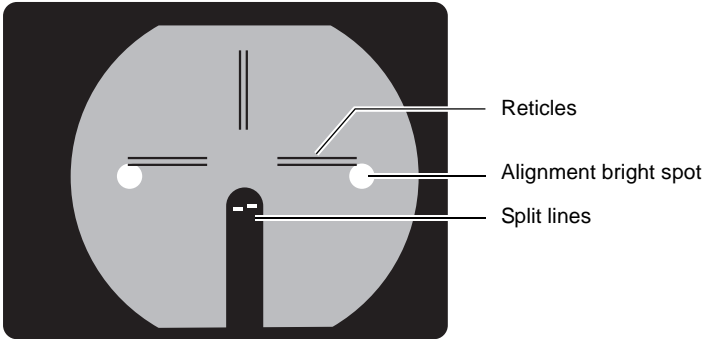



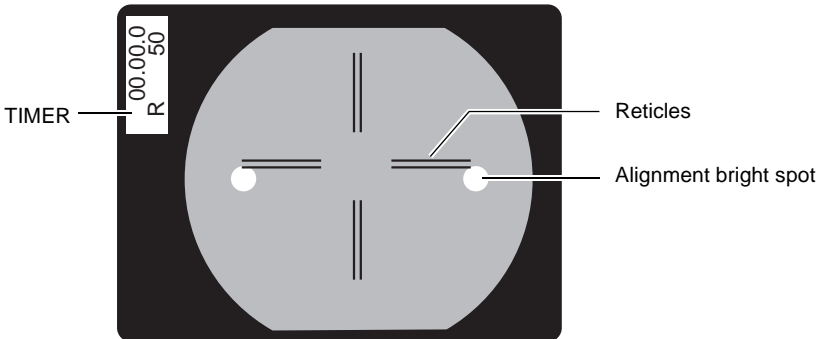

"With split" type

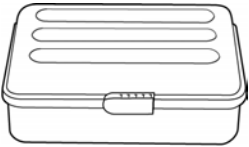
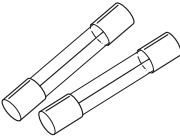
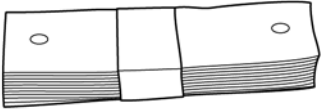
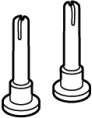
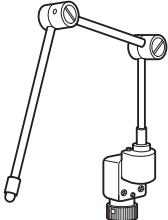
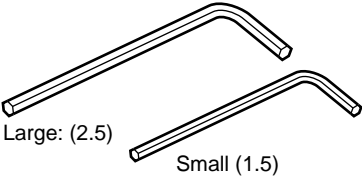

"Without split" type

## STANDARD ACCESSORIES

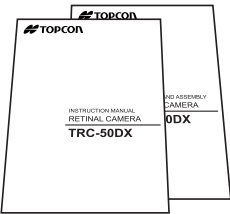
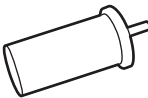
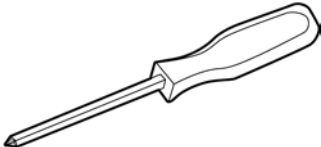
Upon unpacking, make sure that all the following standard accessories are included. Numbers in ( ) are the quantities.

<p>Spare parts case (1)</p> 	<p>Fuse (2)</p> 
<p>Chinrest tissue paper (1)</p> 	<p>Chinrest tissue pin (2)</p> 
<p>External fixation target (1)</p> 	<p>Allen wrench (2)</p>  <p>Large: (2.5) Small (1.5)</p>
<p>Dust cover (1)</p> 	<p>Screw (for main unit connecting cord) (3)</p> 
<p>Instruction manual (1) Unpacking and assembly manual (1)</p> 	<p>Internal fixation target mount (1) (Only in relevant products)</p> 
<p>Phillips screwdriver (1)</p> 	<p>Inclination brake lever (1)</p> 

# SETUP

## CONNECTING THE POWER CORD



### WARNING

To avoid fire and electric shock in case of leakage, be sure to use a grounded receptacle. Do not connect to receptacles that are not grounded.



### CAUTION

To avoid electric shock, do not handle the plugs with wet fingers.

- 1** Make sure that the **POWER SWITCH** on the instrument is in the "OFF" (○) position.

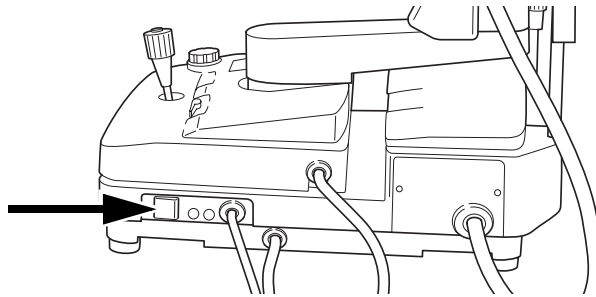

- 2** Connect the power cord into a grounded outlet.

## CONNECTING THE EXTERNAL DEVICE



Consult your dealer for connection with external devices.



Use the external device complying with IEC 60950.

### Connecting to IMAGEnet

This instrument can be connected to IMAGEnet (optional accessory) by two methods.  
Connecting method 1: when using the USB terminal

- 1** Connect one end of the USB cable (optional accessory) to the USB terminal. Connect another end of the USB cable to IMAGEnet. Send the data (right/left eye detection indication, angle of coverage indication, etc.) of the instrument from the USB terminal and receive the data (timer, flash level, etc.) of IMAGEnet.
- 2** Connect one end of the connecting cord (optional accessory) to the CONTROL terminal. Connect another end to IMAGEnet. Performs synchronization.

Connecting method 2: when using the DATA terminal

- 1** Connect one end of the connecting cord (optional accessory) to the DATA terminal. Connect another end of the connecting cord to IMAGEnet. Send the data (right/left eye detection indication, angle of coverage indication, etc.) of the instrument from the DATA terminal.
- 2** Connect one end of the connecting cord (optional accessory) to the CONTROL terminal. Connect another end to IMAGEnet. Performs synchronization.

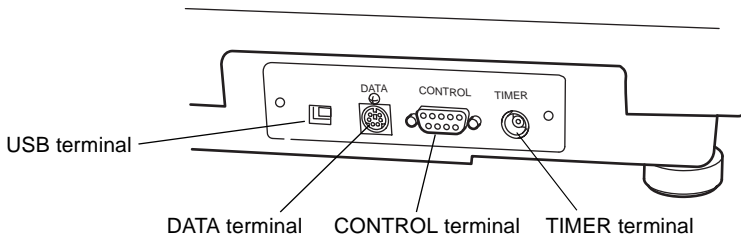

In the U.S. and Canada, use PC which complies with UL60950 or IEC60950.

### Connecting to the video timer

- 1** Connect the timer cable (optional accessory) to the TIMER terminal.
- 2** Connect the timer cable (optional accessory) to the input terminal of the video timer (optional accessory).
- 3** Connect the video signal cable to the input terminal of the external monitor.



Consult your dealer for the details.

In the U.S. and Canada, use video timer or monitor which complies with UL60950 or IEC60950.

## RESET FROM POWER SAVE STATE

This instrument has a power saving feature to save energy.

After 30 minutes of non-use, the instrument switches to power save mode.

In ICG fluorescein photography (only in Type IA), after 60 minutes of non-use, the instrument switches to power save mode.

In the power saving state, "SLEEP" is indicated on the control panel.

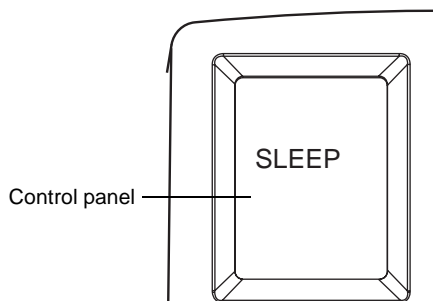

- 1** Press the **PHOTOGRAPHY SWITCH** of the **JOYSTICK** on the base unit.  
After a few seconds, operation is possible.



## SETTING ON THE SET MENU DISPLAY

Setting for the following items can be done on the "SET MENU" display on the control panel: "FLASH LEVEL" (flash level standard setting), "FIX COLOR" (external fixation color selection), "FLICK" (external fixation blinking selection) and "FILTER IN/OUT" (filter link operation method).

- 1 Press the MENU switch  on the setting operation display on the control panel.





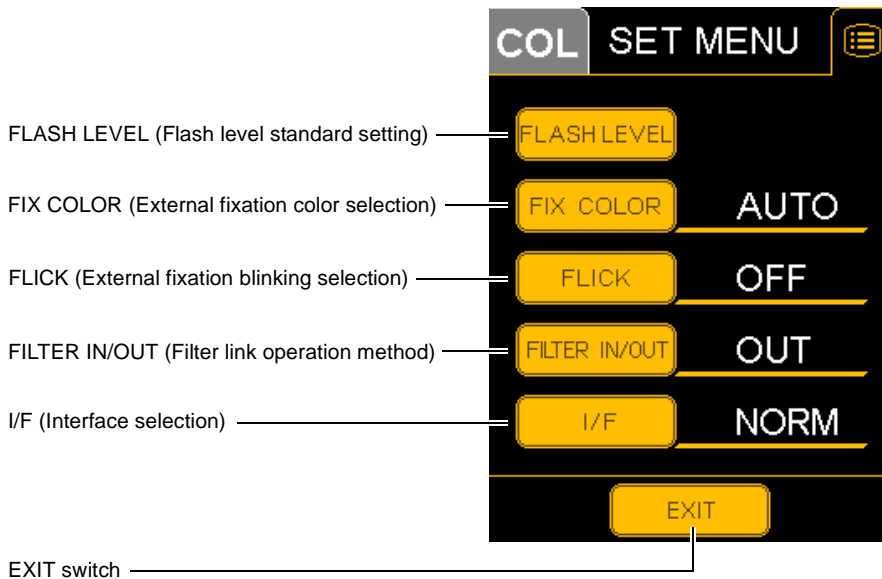

- 2 The "SET MENU" display appears.



- 3 Press the  switch, and the setting operation display appears again.

## FLASH LEVEL (Flash level standard setting)

You can set the flash level standard value for each photography mode. The following table shows the data of the factory default.

- 1 Press the **FLASH LEVEL** on the "SET MENU" display. The "FLASH LEVEL" setting display appears.
  - 2 Touch the value indication window to be changed in each photography mode. Black numbers will appear against a white background.
  - 3 Change the numeral with the  and  switches. Use the  switch to return to the initial value.
  - 4 Press the **MEMORIZE** switch, to store the data. The "SET MENU" display will appear again.
-  If you press the **RETURN** switch, the data will not be stored. The data is reset as before and the "SET MENU" display will appear again.

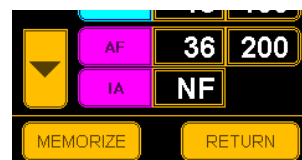
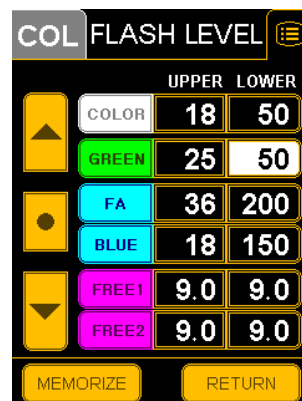

Type IA

Initial values

	UPPER	LOWER
COLOR	18	50
GREEN	25	50
FA	36	200
BLUE	18	150
FREE1	9.0	9.0
FREE2	9.0	9.0

	UPPER	LOWER
COLOR	18	50
GREEN	25	50
FA	36	200
BLUE	18	150
AF	36	200
IA	NF	---

Type IA

## FIX COLOR (External fixation color selection)

You can select "AUTO" (automatic) or "GREEN" or "RED" for the external fixation lamp. "AUTO" is the factory default.

- 1** Press the **FIX COLOR** on the "SET MENU" display. The "FIX COLOR AUTO/GREEN/RED" selection display will appear.
- 2** Press and select **AUTO**, **GREEN** or **RED**. When you select "AUTO", color is automatically selected according to the photography mode.
- 3** Press the **MEMORIZE** switch, to store the data. The "SET MENU" display will appear again.



If you press the **RETURN** switch, the data will not be stored. The data is reset as before and the "SET MENU" display will appear again.



Press the **AUTO** switch, and "GREEN" is set in ICG fluorescein photography and "RED" is set in other photography modes.

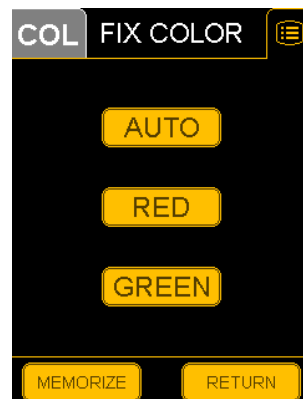

## FLICK (External fixation blinking selection)

You can set the external fixation lamp to "blinking" (ON) or "lighting" (OFF). "OFF" is the factory default.

- 1** Press the **FLICK** switch on the "SET MENU" display. The "FLICK ON/OFF" selection display will appear.
- 2** Press and select **ON** or **OFF**.
- 3** Press the **MEMORIZE** switch, to store the data. The "SET MENU" display will appear again.



If you press the **RETURN** switch, the data will not be stored. The data is reset as before and the "SET MENU" display will appear again.

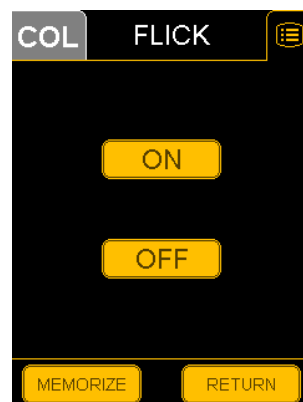

## FILTER IN/OUT

Decide the Ba (barrier) filter or Ex (exciter) filter link operation method. "OUT" is the factory default.

- 1 Press the **FILTER IN/OUT** switch on the "SET MENU" display. The "FILTER IN/OUT" selection display will appear.
- 2 Press and select **IN** or **OUT**. (Refer to the table below.)
- 3 Press the **MEMORIZE** switch, to store the data. The "SET MENU" display will appear again.



If you press the **RETURN** switch, the data will not be stored. The data is reset as before and the "SET MENU" display will appear again.



When you set the link operation of the Ba (barrier) filter and the **PHOTOGRAPHY SWITCH**, the relevant units will operate as shown in the following table because of the relation between the setting for "FILTER IN/OUT" on the "SET MENU" display and the **FILTER** switch on the control panel.

		FILTER switch	
		ON (The background of switch is black.)	OFF (The background of switch is white.)
SET MENU FILTER IN/OUT	IN	Press the <b>PHOTOGRAPHY SWITCH</b> , and the Ba (barrier) filter is inserted and it stays there.	The Ba (barrier) filter is not linked with the <b>PHOTOGRAPHY SWITCH</b> . If you press the Ba (barrier) filter switch, photography with blue filter is possible.
	OUT	Each time you press the <b>PHOTOGRAPHY SWITCH</b> , the Ba (barrier) filter is inserted and removed.	



The **FILTER** switch is displayed when the filter for fluorescein photography is set.

## I/F

Set the interface to "USB" or "NORMAL".  
"NORMAL" is the factory default.

- 1** Press the  switch on the "SET MENU" display. The "USB/NORMAL" selection display will appear.
- 2** Press and select "USB" or "NORMAL".
- 3** Press the  switch, to store the data. The "SET MENU" display will appear again.



If you press the  switch, the data will not be stored. The data is reset as before and the "SET MENU" display will appear again.



Refer to "CONNECTING THE EXTERNAL DEVICE" on page 21. Select "USB" for the connecting method 1, and "NORMAL" for the connecting method 2.

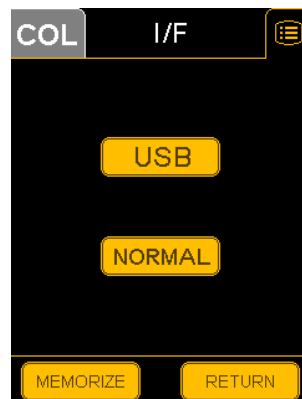

# BASIC OPERATIONS

## PREPARATION FOR PHOTOGRAPHY

- 1** Check the connection of the power cord. Refer to "CONNECTING THE POWER CORD" on page 20 for the connection procedure.
- 2** Set each POWER SWITCH on the instrument and the external record device to the "ON" (I) position.
- 3** Make sure that the instrument is positioned horizontally.  
If the instrument is not set horizontally, incline it up and down until the "Horizontal" index window is red. Swing the instrument right and left and stop it where the direction of the 1st arm is fit to that of the 2nd arm. Refer to "PHOTOGRAPHY BY INCLINATION AND SWINGING" on page 42.

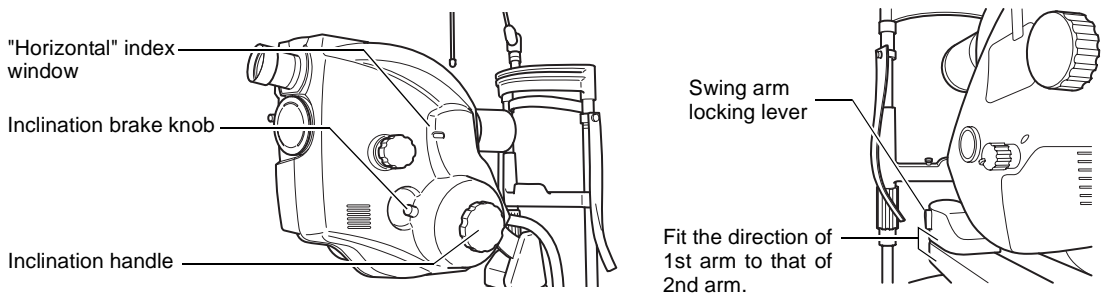

To fix the instrument, tighten the inclination brake knob and swing arm locking lever.

- 4** Adjust the dioptic power of the optical finder.

### **How to adjust the dioptic power:**

Place a white paper in tight contact with the objective lens barrel. (Be careful not to touch the lens.)

Turn the eyepiece lens counterclockwise to put it out fully. Then, gradually turn the eyepiece lens clockwise and, when the reticles (double cross-hairs) are seen clearly, stop turning.

Dioptic power of optical finder

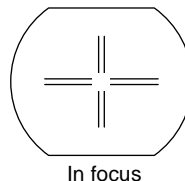
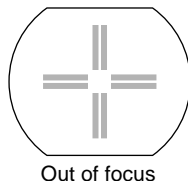

Inaccurate dioptic power adjustment results in unfocused photos.



Refer to "NAMES IN OPTICAL FINDER" on page 18.

## 5 How to move the instrument by the control lever.

- To move the base unit slightly back and forth or right and left, tilt the control lever in the proper direction.

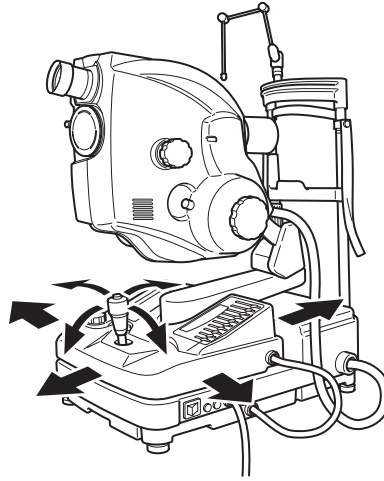

Operation of control lever  
(back and forth/right and left)



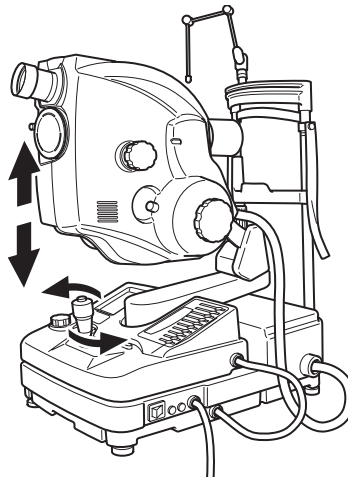

Guiding the base cover with one hand, push the control lever with the other hand in the desired direction. You will move the instrument easily.

- To move the instrument body up and down, turn the control lever clockwise to move it up and counterclockwise to move it down.



Operation of control lever  
(up and down)

## PREPARATION OF THE PATIENT

 <b>CAUTION</b>	To avoid injury while moving the chinrest up and down, instruct the patient to keep hands away from moving parts.
 <b>CAUTION</b>	Be careful not to let the patient hold the column. His/her finger may be pinched between the column and 1st/2nd arm causing injury.
<b>NOTE</b>	Ask the patient to remove any glasses or contact lenses.

- 1 Drop the mydriatic agent in the patient's eyes to achieve full dilation. Make sure that the patient's pupils are fully dilated before beginning photography.



If dilation is inadequate:

When the pupils are only dilated from 4.5mm to 5.5mm, press the **SMALL PUPIL SWITCH**. (If the pupils are dilated to 4.5mm or less, photography is not possible.) Also, photograph at an angle of coverage of 35° or 20°. When photographed at the 50° angle, it may not be possible to eliminate flare completely.

\* Do not use the **SMALL PUPIL SWITCH** in other cases except when dilation of the pupil is inadequate.

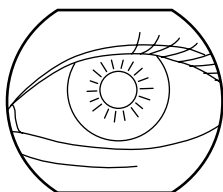

4.5~5.5mm

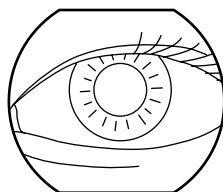

5.5mm or more



- 2 Lead the patient to the photography room.
- 3 Pull the instrument properly to the operator side.
- 4 Let the patient sit down in front of the instrument.
- 5 Adjust the height of the table or the chair so that the patient can relax with his/her chin placed centrally on the chinrest. Then, let the patient rest his/her chin on the chinrest.

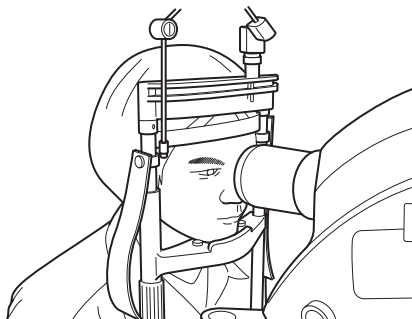





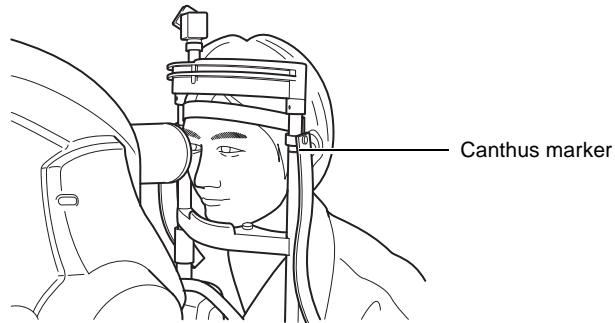



- 6** Adjust the chinrest height by turning the chinrest adjusting knob so that the outside corner of the patient's eye is level with the Canthus marker on the chinrest column. Then, let the patient rest his/her forehead on the forehead rest. Use the headband if necessary. (The headband is installed only in the relevant products.)



- 7** Guide the patient's eye so that the target part of the fundus can be photographed. Guide the patient's eye appropriately by moving the external fixation target. If it is difficult to fix the patient's eye on the target due to myopia or others, turn ON the "FLICK" (External fixation blinking selection) on the "SET MENU" display to blink the external fixation target for fixing the patient's eye more easily. Refer to "FLICK (External fixation blinking selection)" on page 25.

## COLOR PHOTOGRAPHY

 <b>CAUTION</b>	To avoid discomfort or damage to the patient's eye, do not brighten the illumination lamp more than necessary.
 <b>CAUTION</b>	To avoid discomfort or damage to the patient's eye, do not make a flash intensity level higher than necessary.
 <b>CAUTION</b>	To avoid injury while moving the base, do not place your fingers into the gap between the instrument base and the power supply unit.
 <b>CAUTION</b>	To avoid injury while inclining the instrument body, do not place your fingers into the gap between the instrument body and the 1st arm.
 <b>CAUTION</b>	To avoid injury while moving the instrument body, do not place your fingers into the gap between the 1st/2nd arm and the chinrest column. * Please give proper instructions to the patient.
 <b>CAUTION</b>	Pay attention to the clearance between the objective lens and the patient. When the main body is moved, the objective lens may bump against the patient's eye or nose inflicting a minor injury.
<b>NOTE</b>	To ensure correct imaging, adjust the height of the automatic instrument table so that the patient can relax with his/her chin placed centrally on the chinrest.

- 1** Set the **FILTER SWITCHING KNOB** to "N".
- 2** Select the camera with the **UPPER/LOWER SELECTOR SWITCH** of the base unit.
  - In the case of the 35mm camera, check the film.
  - In the case of the video camera, check the recording condition of the camera.

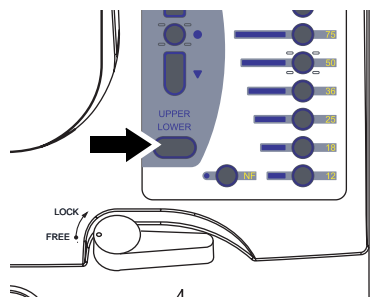

**3** The flash level is automatically changed according to photography modes.



Set the flash level.

Set flash level with the **FLASH SELECTOR SWITCH** and the **FLASH CORRECTION SWITCH**.

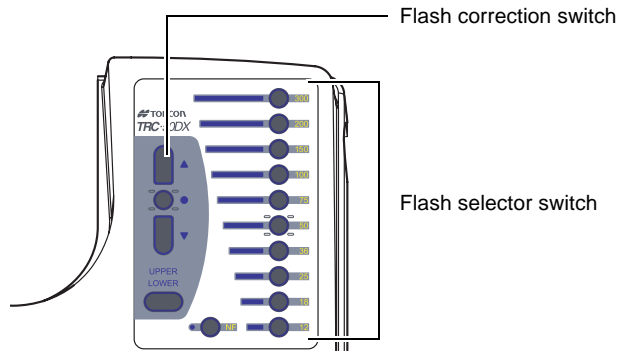

**4** Tell the patient to watch the external fixation target or the internal fixation target (only in Type IA).

**5** Align the illumination light with the patient's pupil.  
Set the illumination level with the **ILLUMINATION LEVEL KNOB**.  
You can check the set level by looking at the illumination level display on the control panel.

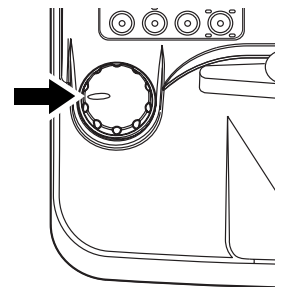

### How to properly align the illumination light:

First look at the patient's pupil from the side of the instrument. To make the illumination light coaxial to the patient's pupil, move roughly the main body to a position about 40mm in front of the patient's eye with the joystick positioned straight, and then, adjust the joystick up and down/right and left. Then, finely adjust the joystick to image the ring slit on the cornea coaxially with the patient's pupil.

- Ring slit images on cornea

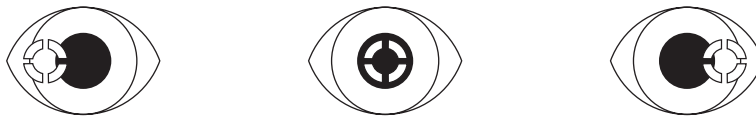

- Images observed by viewfinder

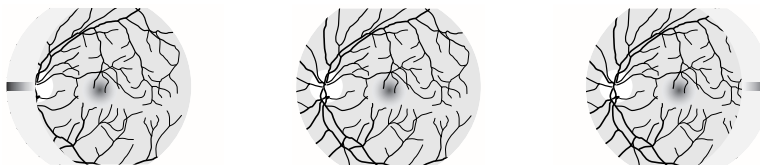

- Images acquired by camera

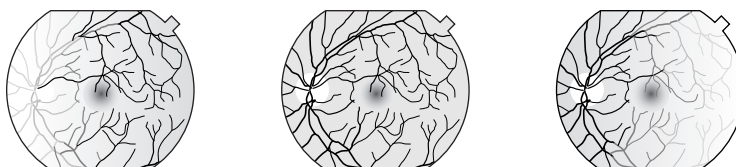

- 6 Push the base unit toward the patient side slowly, and the retinal image is seen in the optical finder.
- 7 Watching the observed image in the optical finder, adjust its brightness with the **ILLUMINATION LEVEL KNOB**.
- 8 Finely adjust the main body forward and backward to illuminate the retina evenly.

• **When the alignment bright spots are used:**

Press the **ALIGNMENT SWITCH** on the control panel.



Move roughly the main body into a position about 40mm in front of the patient's eye with the joystick positioned straight. Then adjust the joystick up and down / right and left until the illumination light becomes coaxial with the patient's pupil. The alignment bright spots will appear on the right and left sides in the optical finder. Make these spots as small as possible.



If the patient moves the eyes or when photographing the periphery by tilting or swinging, sometimes the alignment bright spots on the right and left disappear.

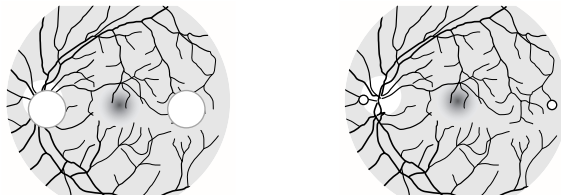

- Adjust alignment so that flares cannot be seen.
- The instrument can be used as mentioned above for the front of 50°.
- When the angle of coverage is changed or when photographing the periphery, it is not possible to use the alignment bright spots.

**9** Focus the retina.

• **How to focus the retinal image with the split lines\* (Only in "With split" type)**

Set the internal fixation target (only in Type IA) to the "OFF" position, and turn on the **SPLIT SWITCH**.

Turn the focusing knob to align the right and left split lines.

\* The split lines cannot be used if the **DIOPTER COMPENSATION LENS SELECTOR** is set other than "0".

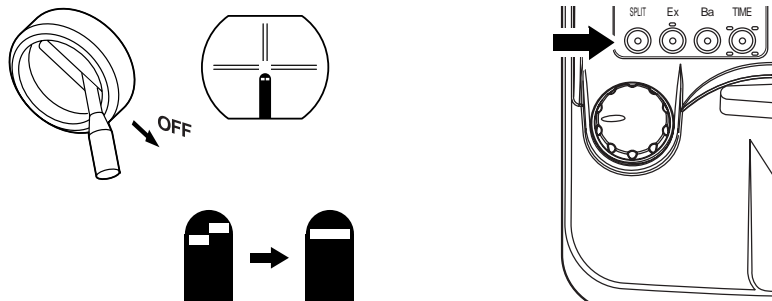



If you cannot align the split lines into one line by operating the focusing knob, change the diopter compensation lens by the diopter compensation lens selector.



If the split lines are not easily visible, lower the illumination level.  
If one of the split lines cannot be seen, check if dilation is sufficient or if the eye is obstructed by eyelashes or the eyelid, interrupting the light.



When the split lines are not necessary, they can be deleted from the optical finder.  
Press the **[SPLIT SWITCH]**, and the split lines disappear from the optical finder.  
Press the **[SPLIT SWITCH]** again, and the split lines are displayed in the optical finder.

• **How to sharply focus the retinal image:**

While looking into the optical finder, turn the focusing knob so that the retinal image and the reticles are observed sharply and distinctly in the field at the same time.

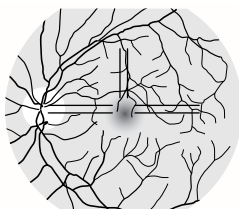

How to adjust focus easily

Press the **[SMALL]** switch of "APERTURE" (photography aperture). (This can be used in color photography and ICG fluorescein photography (only in Type IA).)



How to photograph retinal peripheries

Have the patient watch the external fixation target correctly with the eye that is not being photographed. Then, photograph the peripheries.

It will be possible to photograph the peripheries of the retina, by tilting and/or swinging the main body. (Refer to P. 42.)

When photographing the retinal peripheries, the split lines are deviated. Take a picture so that retina may be in focus.

**10** Set the angle of coverage.

Move the **[ANGLE CHANGING LEVER]** to set the angle of coverage to 50°, 35° or 20°.

To check the angle in use, see the picture angle display on the control panel screen.



Pay attention to the relationship between flare and focus due to difference in angle of coverage. If flare is eliminated at the 50° angle of coverage, no flare occurs at 35° or 20°. Furthermore, refocusing is unnecessary at 50° if the retinal image has already been properly focused at 35° or 20°.

- 11** Make sure that the split line is aligned with the alignment bright spot. Press the **PHOTOGRAPHY SWITCH** when the patient's eye is fully open. Instruct him/her not to blink.

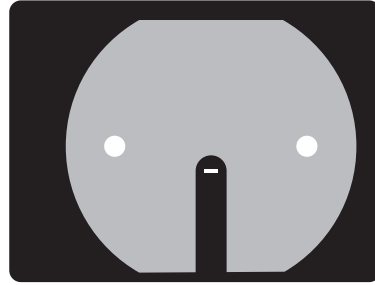
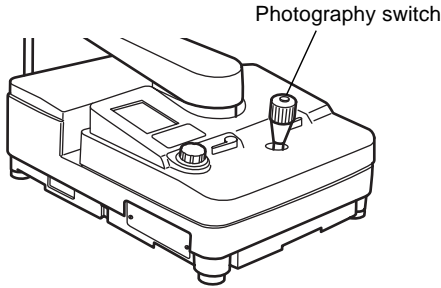

If the light intensity of the photography image is not correct, adjust it with the **FLASH CORRECTION SWITCH** and repeat the alignment and photography procedure.

### How to change the dioptic power compensation

To adjust the dioptic power, turn the **DIOPTER COMPENSATION LENS SELECTOR** according to the patient's eye condition.

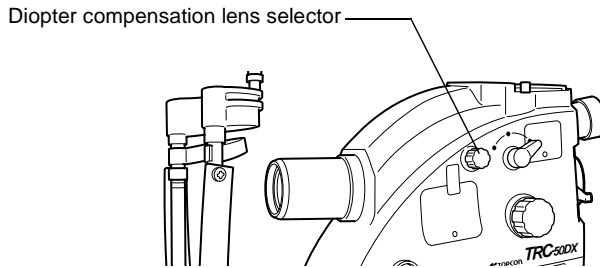

Compensation range	0 : -10D ~ +6D
	- : -23D ~ -9D
	+ : +5D ~ +23D
	A : +22D ~ +41D



When the diopter compensation lens is set to any other values except "0", the split lines are OFF. (Only in "With split" type)

### How to change the dioptic power compensation

**(This correction unit is installed in one type and not installed in another type.)**

According to the astigmatism degree of the patient's eye, pull out the astigmatism correction knob and turn the dial to adjust the astigmatism.

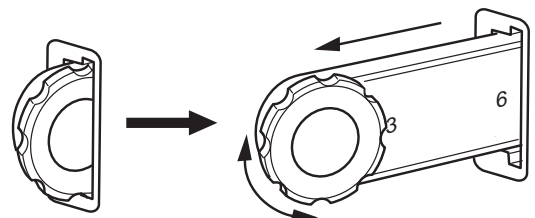

The astigmatism correction is classified into two steps, "3D" and "6D". Push the astigmatism correction knob to the innermost, and the instrument does not correct the astigmatism. Pull out the astigmatism correction knob and set it at "3". The instrument performs the 3D astigmatism correction. Set it at "6", and the instrument performs the 6D astigmatism correction.

## FAG PHOTOGRAPHY

 <b>WARNING</b>	To avoid fire and electric shock, do not put cups or other containers with liquids near the instrument.
<b>NOTE</b>	To ensure correct imaging, adjust the height of the automatic instrument table so that the patient can relax with his/her chin placed centrally on the chinrest.

The basic operation is the same as "COLOR PHOTOGRAPHY". The only difference is the insertion of the fluorescein filters and intravenous injection of fluorescein to the patient.

### Preparation

**1** Set the **FILTER SWITCHING KNOB** to "N".

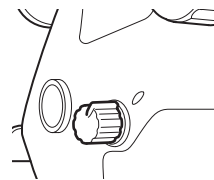

**2** Select the camera with the **UPPER/LOWER SELECTOR SWITCH** of the base unit.

- In the case of the 35mm camera, check the film.
- In the case of the digital camera, check the recording condition of the camera.

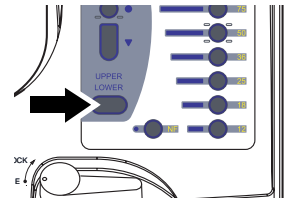

**3** Press the **Ex SWITCH**.

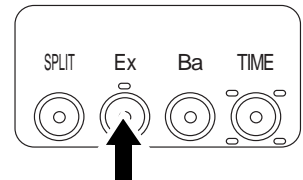

When the barrier filter should be operated in the link condition with the **PHOTOGRAPHY SWITCH**, press the **FILTER SWITCH** on the control panel. The barrier filter will be inserted in a link operation with the **PHOTOGRAPHY SWITCH**.

The link operation is classified into two types. You can select one type on the "SET MENU" display on the control panel. (1) is the factory default. Refer to "FILTER IN/OUT" on page 26 for the details of the setting change method.



- (1) Press the **FILTER SWITCH** while "IN" is selected for "FILTER IN/OUT" on the "SET MENU" display.  
The barrier filter is inserted when pressing the shutter first and it stays.
- (2) Press the **FILTER SWITCH** while "OUT" is selected for "FILTER IN/OUT" on the "SET MENU" display.  
The barrier filter is inserted and removed each time you press the shutter.

**4** Make the same adjustments, as 3~10 for "COLOR PHOTOGRAPHY", and focus the retinal image properly.

**5** Prepare for the intravenous injection of fluorescein.



**How to take distinct fluorescein photographs:**

If too much time is taken in giving the intravenous injection, the fluorescein will be diffused in the blood vessels and diagnostic quality photographs will not be possible.

**6** Press the **TIME SWITCH** at the same time as an intravenous injection of fluorescein is given to the patient.

- When the timer starts, it will beep every second up to 20 seconds.
- Also, the **TIME SWITCH** will blink simultaneously every second until the timer goes OFF.

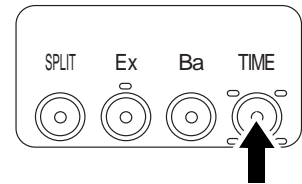

**7** Press the **Ba (BARRIER) SWITCH**.

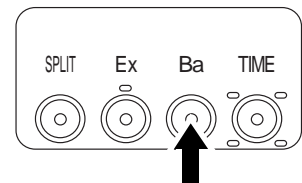

When the **FILTER SWITCH** is ON (white letters on black background), the barrier filter is inserted into the photography unit in a link operation with the **PHOTOGRAPHY SWITCH**.

**8** Press the **PHOTOGRAPHY SWITCH**.

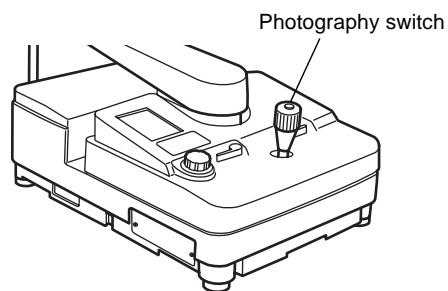

When you keep pressing the **PHOTOGRAPHY SWITCH**, it is possible to take one (1) picture per second.

**9** When you have finished photographing, press the **TIME SWITCH** to stop the timer.



## ICG FLUORESCEIN PHOTOGRAPHY (ONLY IN TYPE IA)



### WARNING

To avoid fire and electric shock, do not put cups or other containers with liquids near the instrument.

### NOTE

To ensure correct imaging, adjust the height of the automatic instrument table so that the patient can relax with his/her chin placed centrally on the chinrest.

The basic operation is the same as "FAG PHOTOGRAPHY". The difference is that observation of the retina is done with the monitor.

**1** Set the **FILTER SWITCHING KNOB** to "IA".



The ICG observation infrared camera is automatically selected.

**2** Make the same adjustments, as **3~10** for "COLOR PHOTOGRAPHY", and focus the retinal image properly.



Select "AUTO" or "GREEN" with the **FIX COLOR** (External fixation color selection) on the "SET MENU" display of the control panel to set the external fixation target color to "green". Near infrared light is used as the illumination light source. So, it is easy to fix the eye on the target by selecting a green fixation target.



The split lines and alignment bright spot are turned off.

**3** Prepare for the intravenous injection of ICG fluorescein.

**4** Press the **TIME SWITCH** at the same time as an intravenous injection of fluorescein is given to the patient.

- The timer starts.

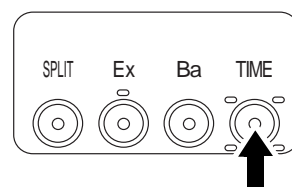

**5** Press the **Ba (BARRIER) SWITCH**.



**When the fluorescein retinal image is fully bright:**

- Press the **SMALL** switch of "APERTURE" (photography aperture), and you can adjust focus easily.

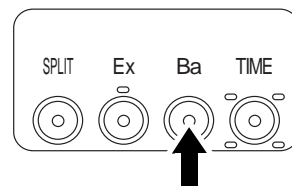

**6** Press the **PHOTOGRAPHY SWITCH**.

**7** When you have finished photographing, press the **TIME SWITCH** to stop the timer.

## RED FREE PHOTOGRAPHY WITH GREEN FILTER (ONLY IN RELEVANT PRODUCTS)

 <b>WARNING</b>	To avoid fire and electric shock, do not put cups or other containers with liquids near the instrument.
<b>NOTE</b>	To ensure correct imaging, adjust the height of the automatic instrument table so that the patient can relax with his/her chin placed centrally on the chinrest.

- 1** Set the **FILTER SWITCHING KNOB** to "G".
- 2** Take a picture according to the same procedure as "COLOR PHOTOGRAPHY".

## AUTO FLUO (AUTO FLUORESCENCE) PHOTOGRAPHY (ONLY IN RELEVANT PRODUCTS)

 <b>WARNING</b>	To avoid fire and electric shock, do not put cups or other containers with liquids near the instrument.
<b>NOTE</b>	To ensure correct imaging, adjust the height of the automatic instrument table so that the patient can relax with his/her chin placed centrally on the chinrest.

In the type without the AUTO FLUO filter, this filter can be installed as an optional accessory. The intravenous injection of fluorescein is not done.

- 1** Set the **FILTER SWITCHING KNOB** to "AF".
- 2** Take a picture according to the same procedure as **2~9** for "FLUORESCEIN PHOTOGRAPHY".
- 3** Press the **Ba (BARRIER SWITCH)**.



When the **FILTER SWITCH** is "ON" (white letters on black background), the barrier filter is inserted into the photography unit by a link operation with the **PHOTOGRAPHY SWITCH**.

**4** Press the **PHOTOGRAPHY SWITCH**.

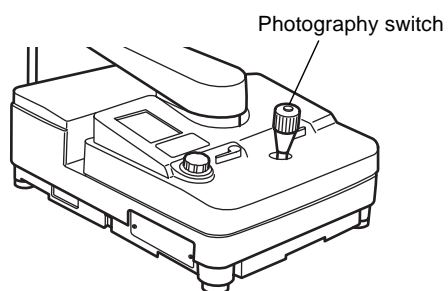

When you keep pressing the **PHOTOGRAPHY SWITCH**, it is possible to take one (1) picture per second.

# OBJECTIVE OPERATIONS

## PHOTOGRAPHY BY INCLINATION AND SWINGING

<b>NOTE</b>	To prevent the instrument from malfunctioning, do not perform inclination and base swinging (right and left) while holding the camera connected to UPPER or LOWER mount.
-------------	--

- 1** When performing inclination, loosen the **INCLINATION BRAKE KNOB** gradually until you can move the **INCLINATION HANDLE**.
- 2** Change the inclined angle of the instrument with the **INCLINATION HANDLE**. The allowable inclined angle is up to 15° in the upper direction and up to 10° in the lower direction.

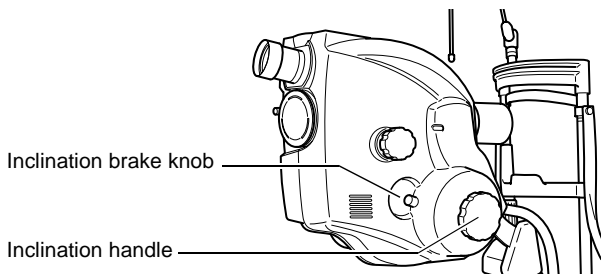

- 3** When performing swinging, loosen the **SWING ARM LOCKING LEVER** on the **2ND ARM**.
- 4** Push the side of the instrument lightly or pull the focusing knob to change the swing angle of the instrument. The allowable swing angle is up to 30° in the right and left direction.

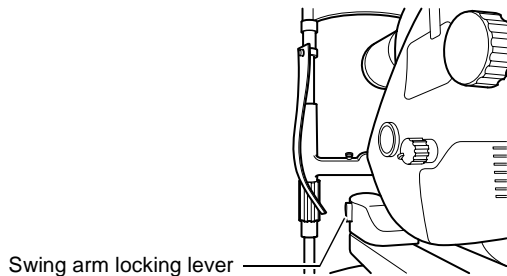

- 5** Perform inclination and swinging until you get a desired position and then take a picture.
  - 6** Perform alignment and photography for the eye according to the same procedure as "COLOR PHOTOGRAPHY".
-  When performing inclination and swinging, the split lines and alignment bright spot should be regarded as standard.

## BLUE FILTER PHOTOGRAPHY

### NOTE

To ensure correct imaging, adjust the height of the automatic instrument table so that the patient can relax with his/her chin placed centrally on the chinrest.

The basic operation is the same as "COLOR PHOTOGRAPHY". It is possible to photograph with the EXCITER filter as the blue filter by setting the **FILTER SWITCH** to "OFF".

- 1 Set the **FILTER SWITCHING KNOB** to "N".
- 2 Press the **FILTER SWITCH** to "OFF" on the control panel. (Black letters will appear on white background.)



The barrier filter is not linked with the shutter.

- 3 Press the **EXCITER SWITCH**.
  - 4 Perform alignment and photography for the eye according to the same procedure as "COLOR PHOTOGRAPHY".
-  Press the **Ba (BARRIER) SWITCH**, and the barrier filter is inserted. Press it again, and the barrier filter retreats.

## PHOTOGRAPHY WITH ALTERNATIVE FILTER (EXCLUDING TYPE IA)

The filter frames F1/F2, which can be installed/removed, are available. Set an alternative filter and take a picture. The basic operation is the same as "RED FREE PHOTOGRAPHY WITH GREEN FILTER" on page 40.



Use a filter which cuts off the ultraviolet rays and infrared rays.



Refer to "How to install the AUTO FLUO Ex filter" on page 63 for changing the filter.

## STEREO PHOTOGRAPHY

Allow the illumination light to come into the patient's pupil so that uniform brightness can be kept on the eye. Then, take a picture using the **STEREO LEVER**. The basic operation is the same as "COLOR PHOTOGRAPHY".

- 1** Align the patient's pupil and the instrument in proper positions.  
Unless the instrument's optical axis aligns with the pupil's optical axis in the up-and-down and right-and-left directions, flares will occur on one side. Be careful.  
Refer to "How to properly align the illumination light" on page 31.  
As flares easily appear at an angle of coverage of 50°, it is suggested that stereo photography is taken at an angle of coverage of 35° or 20°.
- 2** Affix the **STEREO LEVER**.

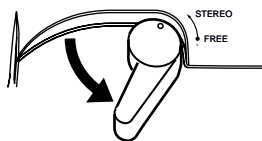

- 3** Move the instrument gently until it stops in the right and left direction and press the **PHOTOGRAPHY SWITCH** (SHUTTER) in each position.



Unless you move the instrument until it stops, the effect of the stereo separation will be reduced.

## **INTERNAL FIXATION TARGET MOUNT (ONLY IN TYPE IA)**

### **Internal fixation target mount (in "With split" type of Type IA)**

- 1** Look into the optical finder and focus the retinal image.
- 2** Turn off the **[SPLIT SWITCH]**.  
\* If the **[SPLIT SWITCH]** is turned on, the knob will be locked.

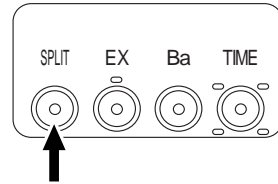

- 3** Move the knob to guide the patient's eye.  
The knob can be pushed and pulled and moved back and forth. The fixation point will move left/right and back/forth by operating the knob. Focusing is not necessary. Move it slowly to guide the patient's eye.
- 4** Perform alignment and photography for the eye according to the same procedure as "COLOR PHOTOGRAPHY".  
\* The fixation point will also be photographed with the retinal image.  
\* When using the SPLIT lines, bring the knob to the "OFF" position and then turn on the **[SPLIT SWITCH]**. If the **[SPLIT SWITCH]** is ON without setting the knob to "OFF", photographs cannot be taken. Be sure to set the knob to the "OFF" position.

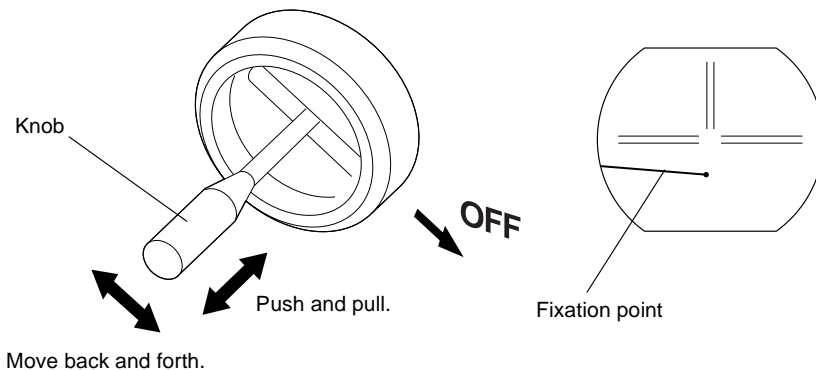

### **Internal fixation target mount (in "Without split" type of Type IA)**

#### **• Operating procedures**

- (1) Move the knob and guide the patient's eye with the fixation point, while checking movement through the finder.**

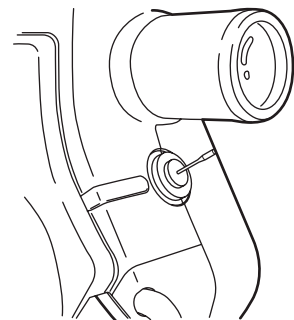

The knob moves in every direction. Up-and-down movement is used for obtaining proper focus, while right-and-left and back-and-forth movements are used to move the fixation point in the finder. Movement should be done slowly, in order not to confuse the patient when guiding the patient's eye.

- Along with the retinal image, the fixation point is also recorded. (Present in the photograph)



# BEFORE REQUESTING SERVICE

## TROUBLESHOOTING

 <b>WARNING</b>	To avoid electric shock, do not attempt disassembling, rebuilding and/ or repairs on your own. Ask your dealer for repairs.
 <b>WARNING</b>	Do not remove the external covers from the main unit, chinrest unit or power supply unit except for the lamp house cover. You may receive an electric shock.

When an error is found, review the Check List below.

If, after following the instructions below, you still have problems or if the problem does not fall into any of the categories below, contact your dealer or TOPCON (see the back cover).

### Check List

Problem	Condition	Check	Page
Periphery of photographed image is dark.	• Operation distance (alignment) is incorrect.	Adjust operation distance (alignment).	29
	• Focusing is incorrect.	Adjust focus.	35
	• Patient's pupil is not large enough.	Darken room and thoroughly dilate patient's pupil.	30
Photographed image is flared all over. (The whole image is covered by light.)	• Operation distance (alignment) is incorrect.	Adjust operation distance (alignment).	29
	• Focusing is incorrect.	Adjust focus.	35
	• Opacity in patient's eye	Flare caused by opacity cannot be removed.	—
Photographed image is whitened.	• Patient blinked the moment the photograph was taken.	Take another picture.	—
Photographed image has a dim white spot.	• Objective lens is stained.	Clean lens.	60
	• Eyelashes were in patient's eye the moment the photograph was taken. (Dim light was seen at screen bottom the moment the alignment was done.)	Let patient open eye wider and take the picture again. If not wide enough, open the eyelid (i.e., Take picture holding eyelid open).	29
Photographic image is dark all over.	• Flash level is insufficient.	Adjust the flash level with the flash correction switch or flash selector switch.	15
	• Xenon lamp set screw is loose.	Fix xenon lamp securely.	55
	• Xenon lamp has served its life.	Change xenon lamp.	55
Illumination lamp does not turn on.	• Power save function is on. ("SLEEP" is indicated on the control panel.)	Press photography switch and cancel power save function.	22
	• Lamp terminal is loose.	Refasten lamp terminal.	54
	• Fuse is burnt.	Change fuse.	57
	• Lamp is burnt.	Change lamp.	54
	• Lamp house cover is not set.	Set Lamp house cover properly.	55
The external fixation target does not light/blink.	• Fuse is burnt.	Change fuse.	57



<b>Problem</b>	<b>Condition</b>	<b>Check</b>	<b>Page</b>
Split lines cannot be seen.	• SPLIT switch is set to OFF.	Turn SPLIT line ON with Split switch.	15
	• Diopter compensation lens selector is not set to "0".	Return Diopter compensation lens selector to "0".	12
	• Patient's pupil is not large enough.	Darken room and thoroughly dilate patient's pupil.	30
	• The internal fixation target is not set to "OFF".	Set the internal fixation target to "OFF".	45
Xenon lamp does not turn on.	• Power save function is on. ("SLEEP" is indicated on the control panel.)	Press photography switch and cancel power save function.	22
	• Xenon lamp has served its life.	Change xenon lamp.	55
	• Fuse is burnt.	Change fuse.	57
	• Xenon lamp set screw is loose.	Refasten lamp terminal.	54
	• The NF switch on the base unit is pressed.	Press Flash selector switch to set the flash level.	33
Cannot get patient's pupil at center.	• Patient's face position is incorrect. (The chin and forehead are not correctly on the rests, or the patient faces sideways.)	Have patient keep his/her position correctly.	30
	• Patient's face height is incorrect.	Adjust face height with Chinrest adjusting knob.	30
Nothing is recorded in external recording device.	• Anomaly in external recording device.	Check power supply, settings, etc.	—
	• Cable connections are incorrect.	Check and correct cable connections.	21
The 35mm UPPER camera does not work.	• Power save function is on ("SLEEP" is indicated on the control panel.)	Press the photography switch to cancel power save function.	22
	• The battery for camera is dead.	Replace the battery.	—
	• Fuse is burnt.	Change fuse.	57
	• UPPER/LOWER selector switch on the base unit is not set to "UPPER".	Press UPPER/LOWER selector switch to set it to "UPPER".	15
	• The 1x relay lens is not attached firmly.	Attach the 1x relay lens firmly.	68
	• The camera is not fixed properly to the 1x relay lens.	Fix the camera on the 1x relay lens properly.	68
Black dots are seen in the photographed image.	• The shading compensation cover is stained.	Perform cleaning with a blower, etc.	—
Flare cannot be eliminated at angle of coverage 50°.	• Angle changing lever is not set at the "click" position.	Turn Angle changing lever to the "click" position.	12
	• The microcoria mode is set because SMALL PUPIL switch is pressed.	Press SMALL PUPIL switch to cancel the microcoria mode.	16
	• The patient's eye and instrument are not positioned correctly.	Set the patient's eye and instrument correctly.	29
	• The patient's eye is not fully dilated.	Dilate the patient's eye fully.	30
Correct focus is not possible.	• The optical finder dioptric power is not adjusted.	Adjust the optical finder dioptric power.	28
	• Diopter compensation lens selector is not adjusted properly for the dioptric power of the patient's eye.	Adjust Diopter compensation lens selector to the dioptric power of the patient's eye properly.	12
	• The patient's eye is clouded due to cataract.		—
	• The patient's eye is filled with tears.		—
	• The patient's eye and instrument are not positioned correctly.	Set the patient's eye and instrument correctly.	29

Problem	Condition	Check	Page
Operator cannot see the patient's eye.	• Illumination light is not ON.	Adjust the illumination level.	33
	• The objective lens cap is set.	Remove the objective lens cap.	—
	• BARRIER filter and EXCITER filter are set to "IN".	Set BARRIER filter and EXCITER filter to "OFF".	15
	• Angle changing lever stops in the middle of the "click" process.	Turn Angle changing lever to the "click" position.	12
	• Diopter compensation lens selector stops in the middle of the "click" process.	Turn Diopter compensation lens selector to the "click" position.	12
Internal fixation target mount does not work.	• SPLIT switch is not set to "OFF".	Set SPLIT switch to "OFF".	15
Photograph of the retinal peripheries is dark.	• The distance between the patient's eye and the instrument is longer than the proper working distance.	Set the patient's eye closer to the instrument and then take a picture.	29
Photograph of retinal center is dark.	• The pupil of the patient's eye is not fully dilated.	Dilate the patient's eye fully.	30
Photograph is influenced by overall flare.	• The distance between the patient's eye and instrument is shorter than the proper working distance.	Set the patient's eye far away from the instrument and then take a picture.	29
	• SMALL PUPIL switch is pressed in angle of coverage 50°.	Press SMALL PUPIL switch to cancel the microcoria mode.	16
	• Flash level is higher than necessary.	Set the flash level to a low value.	33
Vague white dots are seen through the finder and also appear on the photograph.	• Tears or others adhere to the objective lens.	Clean the objective lens.	60

## ERROR CODE LIST

When "Err○○" (○○ means an error number) is displayed in the blinking status on the control panel screen with a beep sound due to an operation error or a malfunction of the instrument, correct the error according to the table below.

Display	Cause	How to correct
Err0	The lamp house cover is opened.	Close the lamp house cover firmly.
Err1	Overcharge or undercharge of charge voltage.	Consult your dealer.
Err2	USB cable is not connected properly.	Check the connection of the USB connector.
Err3	FAG exciter filter does not work properly.	Consult your dealer.
Err4	Nothing (Not used)	Nothing (NA)
Err5	Photography aperture original point sensor does not work properly.	Consult your dealer.
Err6	Barrier filter motor sensor does not work properly.	Consult your dealer.
Err7	Angle sensor does not work properly.	Operate the angle changing lever again.
Err8	The mirror and filter of the TV relay lens do not work properly.	Consult your dealer.
Err9	Desired filter does not work properly.	Operate the desired filter again.
Err10	Illumination aperture does not work properly.	Consult your dealer.
Err11	Internal fixation target does not work properly.	Move the internal fixation target to the "OFF" side.

When any other error except "Err0", "Err2", "Err7", "Err9" and "Err11" is displayed, consult your dealer.

# SPECIFICATIONS AND PERFORMANCE

## SPECIFICATIONS

- Resolving power of the fundus camera  
(Examined eyes 0D, on 35mm film surface)

angle	part	radial	tangential
50°	center	63	63
	middle (r/2)	50	50
	periphery (r)	40	40
35°	center	80	80
	middle (r/2)	63	63
	periphery (r)	50	50
20°	center	100	100
	middle (r/2)	80	80
	periphery (r)	63	63

unit : lp/mm

- Angle of coverage : 50°/35°/20°
- Photography magnification : When the patient's eye is 0D, 35mm film is used:  
50°: 1.84x  
35°: 2.45x  
20°: 4.28x
- Dioptic power adjustment range of optical finder : -6D ~ +5D
- Focus range to compensate the refraction trouble of the patient's eye :  
0 : -10D ~ +6D  
- : -23D ~ -9D  
+ : +5D ~ +23D  
A : +22D ~ +41D
- Operating distance : 39.0mm
- Base movement  
Back and forth : 80mm  
Right and left : 110mm  
Fine movement : 12mm  
Up and down : 30mm
- Up-and-down inclined angle : Upper 15°/Lower 10°

\* The specifications and design are subject to change without prior notice for improvement.

## ELECTRIC RATING

Source voltage : 100-120V/200-240V FREQ. 50-60Hz  
Power : 1500VA

## **SYSTEM CLASSIFICATION**

- Types of protection against electric shocks:  
This instrument is classified as Class I equipment.  
Class I equipment does not depend only on basic insulation for protection against electric shocks, but also provides a means of connection to a protective earth system of facilities so that metal parts that come into contact do not become conductive while the basic insulation is in failure.
- Degree of protection against electric shocks: Type B applied part  
Type B applied part is the applied part complying with the specified requirements of the Standard IEC 60601-1 to provide protection against electric shock, particularly regarding allowable LEAKAGE CURRENT.
- Degree of protection against harmful ingress of water: IPx0  
The TRC-50DX has no protection against ingress of water. (The degree of protection against harmful ingress of water defined in IEC 60529 is IPx0.)
- Classification according to the method(s) of sterilization or disinfection recommended by the manufacturer: not applicable.  
The TRC-50DX has no part to be sterilized or to be disinfected.
- Classification according to the degree of safety of application in the presence of a flammable anesthetic mixture with air or with oxygen or nitrous oxide: Equipment not suitable for use in the presence of a flammable anesthetic mixture with air or with oxygen or nitrous oxide.  
The TRC-50DX should be used in environments where no flammable anesthetics and/or flammable gases are present.
- Classification according to the mode of operation: Continuous operation.  
Continuous operation is the operation under normal load for an unlimited period, without the specified limits of temperature being exceeded.

## **DIMENSIONS AND WEIGHT**

Dimensions : 340mm (W) × 505mm (D) × 506~715mm (H)  
Weight : 35kg (only the instrument)

## **PURPOSE OF USE**

To observe, take pictures or record pictures of the posterior segment of the eye through the pupil.

## **OPERATION PRINCIPLE**

The observation light emitted from the illumination optical system illuminates the patient's eye (the eye to be photographed), and the image formed by the observation/photography optical systems is observed. By operating the photography switch on the instrument, the photography light is emitted from the illumination optical system to illuminate the patient's eye. The image formed by the observation/photography optical systems is photographed and recorded by the 35mm film camera (a product in the market) or an electronic photography device (a product in the market).

The following filters, which can be installed/removed, are built in the illumination optical system: One is the Ex filter and this selects and transmits the light that excites the fluorescent coloring matter in FAG photography. The other is the ICG-Ex filter and this selects and transmits the infrared light that excites the fluorescent coloring matter in ICG fluorescein photography. (The ICG-Ex filter is built in only Type IA.)

The following filters are built in the observation/photography optical systems: One is the Ba filter and this selects and filtrates the fluorescent wavelength in FAG photography. The other is the ICG-Ba filter and this selects and filtrates the fluorescent wavelength in ICG fluorescein photography. (The ICG-Ba filter is built in only Type IA.)

The angle of coverage can be changed by changing the lens located in the observation/photography optical systems. The illumination aperture located in the illumination optical system is changed in the link operation with the change of the angle of coverage. So, the illumination level is adjusted properly for photography.

The photography aperture located in the observation/photography optical systems is changed properly for photography according to the photography technique.

# MAINTENANCE



**CAUTION**

To prevent damage and injuries, do not install the instrument on an uneven, unsteady or sloped surface.

## DAILY CHECKUPS

- Before using this instrument, always inspect it.
- Each time you use this instrument, clean it according to "CLEANING" on page 60.
- Dust is a formidable foe to the instrument.
- To ensure the production of fine images, care should be taken not to allow fingerprints and/or dirt on the objective lens.
- When not in use, be sure to cap the objective lens and cover the instrument with the dust cover.
- Before using the instrument, check if the objective lens is clean. If the objective lens is stained, clean it following the instructions for "CLEANING THE OBJECTIVE LENS" on page 60.
- When not in use, always turn the POWER SWITCH OFF.

## ORDERING CONSUMABLES

- When ordering consumables and spare parts, contact your dealer or TOPCON (see the back cover) and tell them the article name, article code and quantity.



Article name	Article code
Illumination lamp	40535 40200
Xenon lamp	40413 16200
Chinrest tissue paper	40310 4082
Dust cover	40488 1007

Article name	Article code
Fuse 15A 125V (for 100V/120V)	T24000086A
8A 250V (for 230V)	T24000085A

## MAINTENANCE BY THE DEALER

Item	Inspection interval	Details
Cleaning each unit	Within 12 months from the last maintenance	<ul style="list-style-type: none"> <li>• Cleaning the external section</li> <li>• Cleaning the optical system</li> <li>• Cleaning the base unit</li> </ul>
Checking the operation	Within 12 months from the last maintenance	<ul style="list-style-type: none"> <li>• Operation of the main body</li> <li>• Operation of the switches</li> </ul>
Checking photography	Within 12 months from the last maintenance	<ul style="list-style-type: none"> <li>• Focus, flare, center ghost and dust</li> <li>• Checking the xenon light intensity (by the special tool)</li> </ul>

## REPLACING THE ILLUMINATION LAMP

 <b>CAUTION</b>	To avoid electric shock, be sure to turn the power switch off and unplug the power cord before replacing the lamp.
 <b>CAUTION</b>	To avoid burns, do not replace the lamp with a new one immediately after it goes off. Allow time for it to cool.
<b>NOTE</b>	To avoid whitening due to fingerprints, do not touch the lamp with bare fingers.
<b>NOTE</b>	Since the lamp is not resistible to shocks, handle it with particular care. Do not drop.

- The service life of the illumination lamp is approx. 2000 hours.  
Replace the illumination lamp if it is burned out or becomes whitened.

- 1** Turn the **POWER SWITCH** OFF and unplug the power cord.
- 2** Turn the control lever to raise the instrument body to its limit.
- 3** Remove the screw. Then, push the bottom of the lamp house cover and pull it forward to remove it.

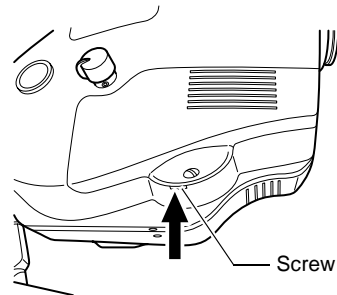
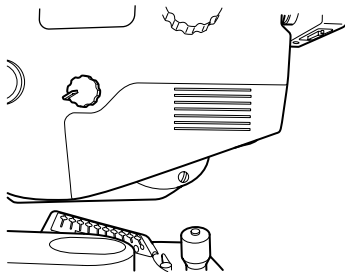

- 4** Loosen the two fixing screws and pull out the illumination lamp unit straight.

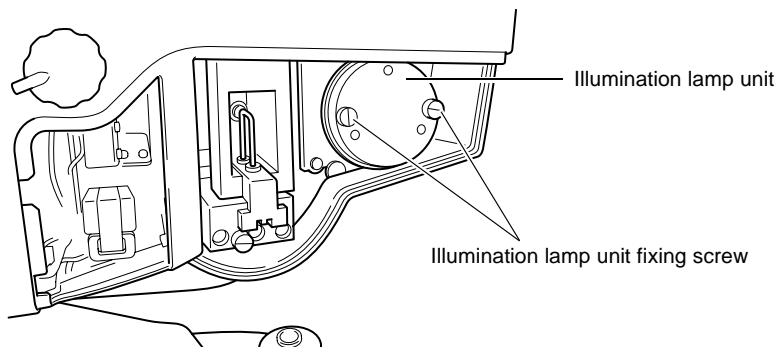



- 5** Insert the new illumination lamp straight and tighten securely the two fixing screws of the illumination lamp.
  - 6** Attach the lamp house cover by matching the projection at the bottom part of the lamp house cover with the groove of the body cover.
-  If the lamp house cover is left unfixed, an error is displayed on the control panel and operations, including photography, cannot be done.

## **REPLACING THE XENON LAMP**

<b>! CAUTION</b>	To avoid electric shock, be sure to turn the power switch off and unplug the power cord before replacing the lamp.
<b>! CAUTION</b>	To avoid electric shock, do not replace the xenon lamp with a new one immediately after it goes off.
<b>NOTE</b>	To avoid whitening due to fingerprints, do not touch the lamp with bare fingers.
<b>NOTE</b>	Since the lamp is not resistible to shocks, handle it with particular care. Do not drop.

- The service life of the xenon lamp is approx. 10000 flashes.  
Replace the xenon lamp if it is burned out or becomes whitened.
- 1** Turn the **POWER SWITCH** OFF and unplug the power cord, then wait for more than 5 minutes for the natural electrical discharge.
  - 2** Push the bottom of the lamp house cover and pull it forward to remove it.
  - 3** Remove the xenon lamp set screw by turning it counterclockwise with a coin.

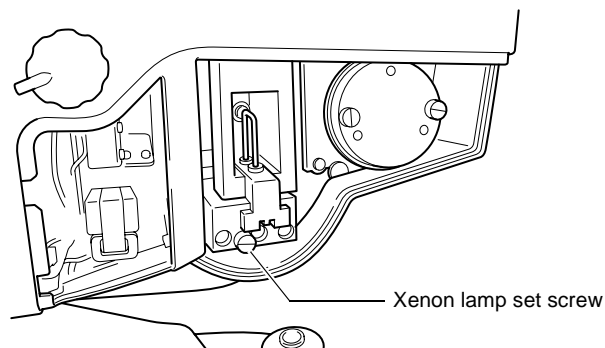

- 4** Slowly pull the xenon lamp straight out.
- 5** Insert the new xenon lamp straight in the receptacle until it reaches the end.
- 6** Tighten the xenon lamp set screw fully with a coin clockwise.
- 7** Attach the lamp house cover by matching the projection at the bottom part of the lamp house cover with the groove of the body cover.



If the lamp house cover is left unfixed, an error is displayed on the control panel and operations, including photography, cannot be done.

## REPLACING THE FUSE



### WARNING

To avoid electric shock when replacing the fuse, be sure to unplug the instrument before removing the fuse cover. Do not use ungrounded outlets. Do not plug in the instrument without the fuse cover.



### WARNING

To avoid fire in the event of an instrument malfunction, use only the fuses that are marked with the label at the side of the fuse holder.

- 1 Turn the **POWER SWITCH** OFF and unplug the power cord.
- 2 With a slotted screwdriver, press and turn the fuse holder counterclockwise and remove it.

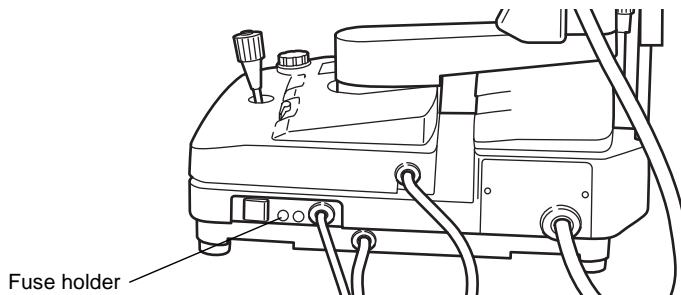

- 3 Replace the fuse with a new fuse of the same capacity.

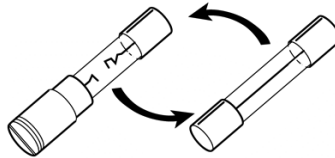

Changing the fuse

- 4 With a slotted screwdriver, lightly press and turn the fuse holder clockwise and fasten it.





If the fuse has blown out, the whole instrument will not operate. Replace the fuse with a new one.

## REFILLING THE CHINREST TISSUE PAPER

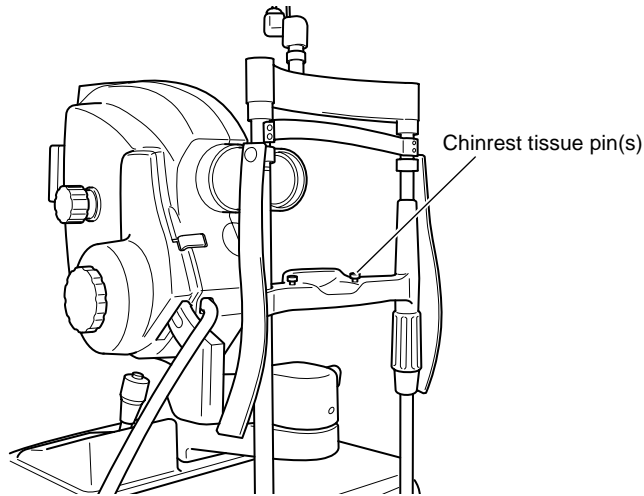
- When the chinrest tissue paper is used up, pull out the chinrest tissue pins and refill the tissue paper.



## THE FAG FLUORESCHEIN FILTER

 <b>CAUTION</b>	To avoid electric shock, be sure to turn the power switch off and unplug the power cord before replacing the filter.
 <b>CAUTION</b>	To avoid burns due to the hot filter unit, do not replace the filter with a new one immediately after the power goes off.
<b>NOTE</b>	To prevent the glass from whitening due to fingerprints, do not touch the filter with bare fingers.
<b>NOTE</b>	Since the filter is not resistible to shocks, handle it with particular care.

### How to install the Ex (exciter) filter

- 1** Turn the **POWER SWITCH** ON (I).
- 2** Set the **FILTER SWITCHING KNOB** to "N".
- 3** Press the **Ex SWITCH**.
- 4** Turn the **POWER SWITCH** OFF (O).
- 5** Turn the control lever to raise the instrument body to its limit.
- 6** Remove the lamp house cover screw. Then, push the bottom of the lamp house cover and pull it forward to remove it.
- 7** Hold the grip of the filter frame with fingers and pull it out straight.

**8** Install the filter into the filter frame.



It is not necessary to distinguish between the front and rear of the filter.



After installing the filter into the filter frame, apply the adhesive to the outer circumference of the filter. Consult your dealer for the adhesive.

**9** Insert the filter firmly.



Hold the filter mounting metal plate to prevent it from moving.



Be careful not to damage or stain the filter with fingerprint.

**10** Set the lamp house cover in the reversed procedure of the removal.

### How to install the Ba (barrier) filter

The method is the same as "How to install the AUTO FLUO Ba filter" on page 64. The difference is that the filter frame display is "FA".



Be careful not to mistake it as "AF" (AUTO FLUO).

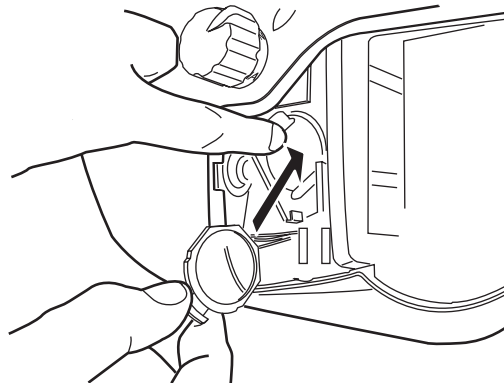

# CLEANING

- Before using this instrument, always clean it.

## CLEANING THE EXTERNAL COVER, CONTROL PANEL AND OTHERS

<b>NOTE</b>	<ul style="list-style-type: none"><li>• To prevent the plastic parts of the instrument body from discoloring and deteriorating, do not use volatile solvents for cleaning, including benzine, thinner, ether, gasoline, etc.</li></ul>
-------------	--

- 1** When the external cover and control panel become stained, clean them with a dry cloth.
- 2** If the external cover is badly stained, prepare a tepid solution of neutral detergent for kitchenware. Moisten the cloth with the aforementioned solution and wring it thoroughly. Then wipe the cover with the cloth.

## CLEANING THE PARTS WHICH COME INTO CONTACT WITH THE PATIENT

- Stain on forehead rest and chinrest  
Mix the neutral detergent for kitchenware in tepid water. Moisten the cloth with the aforementioned solution and wring it thoroughly. Then, wipe the forehead and chinrest with the cloth.

## CLEANING THE OBJECTIVE LENS

- To check the objective lens, set the **POWER SWITCH** to "ON" (I) and turn the illumination lamp ON.  
Darken the room. Turn the **ILLUMINATION LEVEL KNOB** to adjust the light intensity.  
Examine the objective lens diagonally from the front. The lens condition can be seen clearly.

### **How to wipe the objective lens**

The wiping method is different from the conventional coated lens. The resistance against wiping is very low and the lens is smooth.

- When dust and dirt adhere to the surface:  
Blow them off using a blower.  
Be careful to prevent the blower end from touching the objective lens.
- When the stain is simple such as dust, tears or saliva:

- 1** Breathe toward the objective lens and wipe it with a lens cleaning paper carefully.
- 2** If your lens cleaning paper is dirty, replace it with a clean one and repeat step **1**.
- 3** Repeat steps **1** and **2** until no stain is seen on the lens.

- When the stain is persistent:

- 1** Moisten a lens cleaning paper with reagent ethanol properly. Wipe the objective lens with the lens cleaning paper by rubbing lightly.
- 2** If your lens cleaning paper is dirty, replace it with clean one and repeat step **1**.
- 3** Repeat steps **1** and **2** until no stain is seen on the lens.
- 4** Finally, wipe the objective lens with a dry lens cleaning paper which is not moistened with solvent until it is clean. It is permitted to wipe the lens after breathing on it.



Don't use the following methods because the lens can be damaged.

- Wiping the lens by grasping with fingernails
- Using a lens cleaning paper wound around a hard tool (for example, a metallic tool)



Use a soft lens cleaning paper without fiber.

- For example, BEMCOT (Asahikasei)



Don't let any strong-alkaline liquid adhere to the objective lens.

If such liquid adheres to the lens, immediately wipe it off.



If it is difficult to remove a stain from the objective lens, contact your dealer or TOPCON (see the back cover).

## **CLEANING THE LENS WHICH IS SEEN IN UPPER MOUNT**

Dust or other impurities adhering to the lens, which is seen in the mount, may be reflected in the retinal images photographed. In this case, clean the lens by the following method.

### **Cleaning the outside of lens**

- 1** Blow dust or other impurities using a blower.
- 2** If stain is persistent, wipe the lens with a lens cleaner.
  - a) Prepare a mixed solution with a ratio of 2 (ethyl alcohol) to 8 (ether).
  - b) Moisten a clean gauze (already washed and dried) with this solution. By using this gauze, gently wipe the lens in a circular direction from its center to outside.
  - c) If stain still remains, wipe the lens repeatedly.



If you wipe or rub the dirty lens violently, its surface will be damaged. During cleaning, be careful not to damage the mask.

### **Cleaning the inside of the lens**

- 1** If the inside of the lens is stained, remove the shading compensation cover screw with a slotted screwdriver. Remove the shading compensation cover and then clean the lens.

# OPTIONAL ACCESSORIES

The optional accessories for TRC-50DX enable a variety of photography.

 <b>CAUTION</b>	Ensure that the 35mm camera is installed firmly by fastening the 35mm camera body locking lever. If installed loosely, the camera may fall off, resulting in severe damage to the unit and bodily injury.
 <b>CAUTION</b>	When installing accessories, secure them firmly by fastening the accessory locking lever. If installed loosely, the accessories may fall off, leading to bodily injury.
 <b>CAUTION</b>	To avoid injury, remove the accessories of the UPPER mount before carrying the instrument. The instrument may tip over.
<b>NOTE</b>	Before installing/removing the accessories, lock the inclination mechanism. If removing an accessory without locking it, the optical unit moves up. Moreover, when installing an accessory, the optical unit moves and so it is difficult to install it.

## **1x relay lens adapter OR-2**

Used when installing the 35mm film camera (a product in the market) onto the UPPER mount.

## **TV relay lens adapter**

Refer to "Video relay lens list" on P.70.

Used when installing the commercial electronic photography device onto the UPPER mount.

## **TM conversion adapter MD-2**

Used when installing the commercial electronic photography device onto the LOWER mount.

## **AUTO FLUO filter attachment AF-1**

This set consists of the exciter filter and barrier filter for auto fluorescence photography.

## **Internal fixation target mount**

Used in the "Without split" type.



## OPTIONAL ACCESSORY MOUNTING/DETACHING METHODS

### How to install/remove the 1x relay lens adapter/video relay lens adapter

#### Mounting method

- 1** Lock the base fixing lever and the inclination brake knob.
- 2** Turn the UPPER mount locking lever to remove the cap.
- 3** Remove the cap from the optional accessory and install it onto the instrument body. Stand next to the instrument body and install the optional accessory straight from above with both hands. Turn the UPPER mount locking lever to fix it.
- 4** Install the commercial 35mm film camera or electronic photography device.
- 5** Connect the cables.

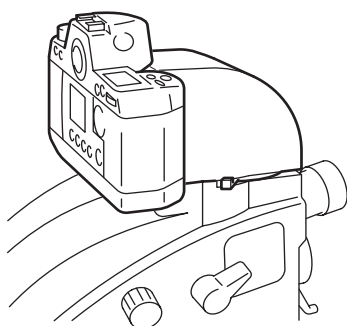

#### Detaching method

- 1** Remove the lens adapter in the reversed procedure of "Mounting method".

### How to install/remove the TM conversion adapter



#### Mounting method

- 1** Lock the base fixing lever and the inclination brake knob.
- 2** Turn the LOWER mount locking lever to remove the cap.
- 3** Install the commercial electronic photography device onto the TM conversion adapter. Then, install the TM conversion adapter onto the LOWER mount. Turn the LOWER mount locking lever to fix it.
- 4** Connect the cables.





#### Detaching method

- 1** Remove the TM conversion adapter in the reversed procedure of "Mounting method".

## Installing/removing the AUTO FLUO filter attachment

 <b>CAUTION</b>	To avoid electric shock, be sure to turn the power switch off and unplug the power cord before replacing the filter.
 <b>CAUTION</b>	To avoid burns due to the hot filter unit, do not replace the filter with a new one immediately after the power goes off.
<b>NOTE</b>	To prevent the glass from whitening due to fingerprints, do not touch the filter with bare fingers.
<b>NOTE</b>	Since the filter is not resistible to shocks, handle it with particular care.

### How to install the AUTO FLUO Ex filter

- 1 Turn the **POWER SWITCH** OFF (○) and unplug the power cord.
- 2 Turn the control lever to raise the instrument body to its limit.
- 3 Remove the lamp house cover screw. Then, push the bottom of the lamp house cover and pull it forward to remove it.
- 4 Set the **FILTER SWITCHING KNOB** to "F1".
  -  At this time, the filter frame "F1" is positioned at the lowest section of the turret.
  -  The oil adheres on the outer circumference of the turret. Do not touch it.
- 5 To take out the filter frame easily, turn the **FILTER SWITCHING KNOB** in approx. 45° counter-clockwise.
- 6 Hold the projection of the filter frame with radio pliers, etc. and pull it out straight.
- 7 Hold the projection of the frame on the AUTO FLUO Ex filter (optional accessory) with radio pliers, etc. and put it into the turret.
  -  It is not necessary to distinguish between the front and rear of the filter.
  -  Set the filter frame to the innermost correctly. Turn the **FILTER SWITCHING KNOB** to make sure that it is not caught by anything.
  -  Be careful not to damage or stain the filter with fingerprint.
- 8 Set the lamp house cover in the reversed procedure of the removal.

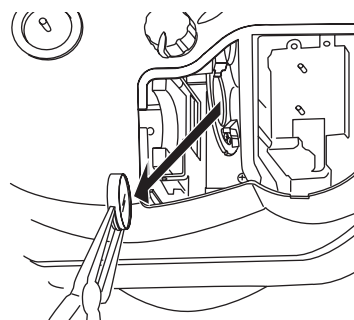

## How to install the AUTO FLUO Ba filter

- 1** Turn the **POWER SWITCH** OFF (○) and unplug the power cord.
- 2** Remove the barrier filter cover screw. Then, remove the barrier filter cover.
- 3** Turn the turret by fingers. Hold the filter frame showing "F" with your fingers or radio pliers and pull it out straight.

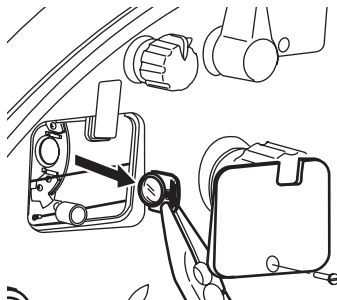

- 4** Hold the frame of the AUTO FLUO Ba filter (optional accessory) with your fingers or radio pliers and put it into the turret.



It is not necessary to distinguish between the front and rear of the filter.



Set the filter frame to the innermost correctly. Turn the turret with your fingers to make sure that it is not caught by anything.



Be careful not to damage or stain the filter with fingerprint.



Be careful not to touch the wires.

- 5** Set the barrier filter cover in the reversed procedure of the removal.

## Check after installing the AUTO FLUO filter attachment

- 1** Plug in the power cord and turn the **POWER SWITCH** ON (|).
- 2** Set the **FILTER SWITCHING KNOB** to "F1".
- 3** Make sure that the yellow illumination light is emitted from the objective lens.
- 4** Press the **Ba (BARRIER) SWITCH** to make sure that the background which is seen through the optical finder is dark.

## How to install the internal fixation target mount

(for "without split" type)

- Nomenclature

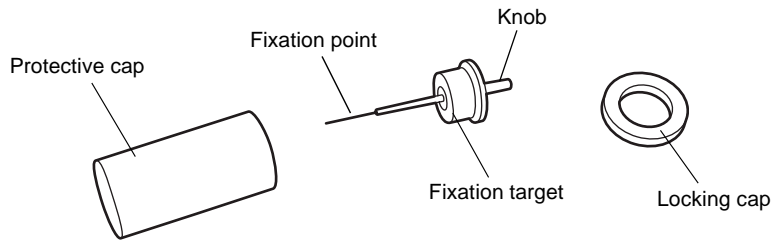

- How to attach the Internal Fixation Target

- (1) Take off the cover of the internal fixation target mount on the main body of retinal camera.

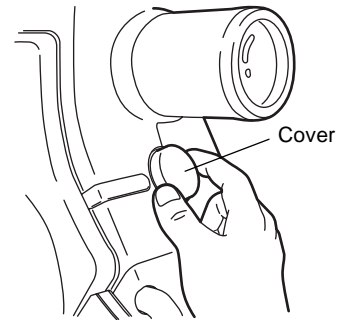

- (2) Take off the protective cap, align the fixation target with pin of the internal fixation target mount and insert straightly into the main body.

In the above case, great care must be exercised because the fixation point is slender and easily bent. For attachment, the fixation point should be pulled out as fully as possible, and the mount should be screwed in slowly and carefully, with the fixation point maintained vertically. And, until the locking cap is attached, the fixation point should not be moved.

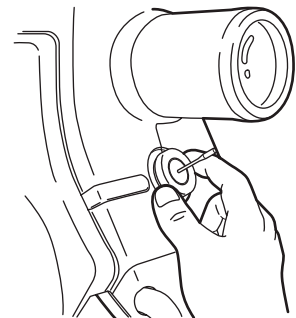

- (3) Tighten the locking cap.

## **ACCESSORY LENS CLEANING METHODS**

Dust or other impurities adhering to the lens, which is seen in the mount, may be reflected in the retinal images photographed. In the presence of such impurities, the lens must be cleaned according to the methods specified below.

### **Cleaning the outer side of the lens:**

- 1** Blow off dust or other impurities with a hand blower.
- 2** If stain is persistent, wipe it off with a lens cleaner.
  - a) Prepare a mixed solution at the ratio of 2 (ethyl alcohol) to 8 (ether).
  - b) Moisten a clean gauze (already washed and dried) with the mixed solution. By using this gauze, gently wipe the lens in a circular direction from its center to outside.
  - c) If stain still remains, wipe the lens repeatedly.

If you wipe or rub the dirty lens violently, its surface will be damaged. During cleaning, be careful not to damage the mask.

### **Cleaning the inside of the lens:**

- 1** Loosen the machine screws (3 pcs.) from the mount and pull the mount straight out in the arrow direction.  
In the case of the TV relay lens adapter, one of the three machine screws is located inside the side cover.
- 2** Blow off dust or other impurities with a hand blower or wipe it with a lens cleaner.  
When cleaning the TV relay lens adapter, the cover glass on the lens must be cleaned.
- 3** Reinstall the mount.  
Insert the mount straight, so that the mount positioning pin aligns with the slot. Tighten the machine screws.

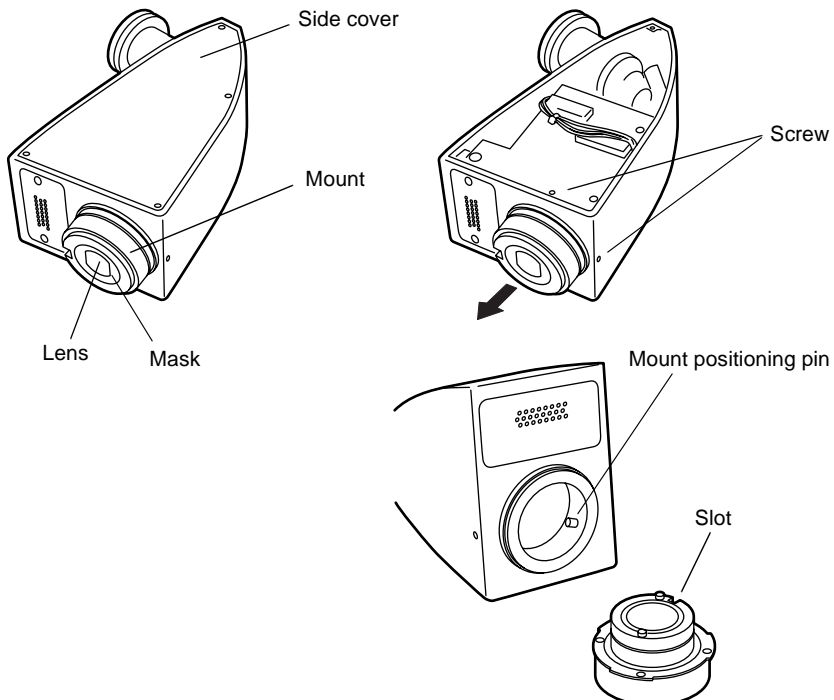

## **1x RELAY LENS ADAPTER OR-2**

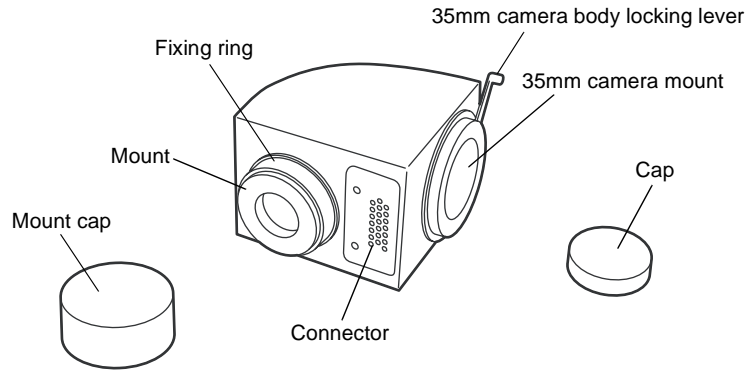

### **Photography method**

- 1** Set the UPPER/LOWER SELECTOR SWITCH to "UPPER" on the control panel.
- 2** Perform alignment and photography for retina in the same procedure as "COLOR PHOTOGRAPHY" or "FAG PHOTOGRAPHY".
  - Size..... 106 (W) × 140 (D) × 141 (H) mm



Set the shutter speed to "1/30 sec." for the 35mm film camera (a product in the market).

## **TV RELAY LENS ADAPTER**

### **• Precautions and suggestions to use**

Be careful not to use an improper video camera.

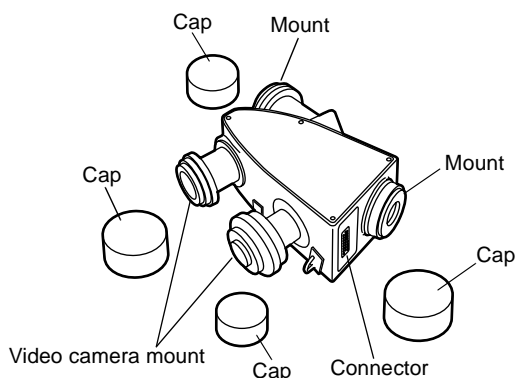

### **• How to attach the video camera**

See the instruction manual for video camera.

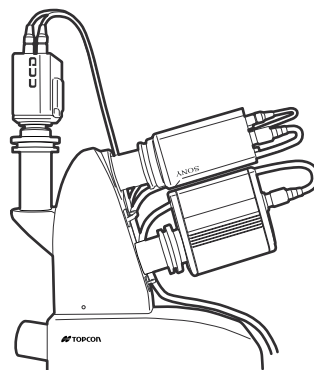

### **• Cable connection**

Insert the cable into the cable holder on the main body.

- Do not pull up the cable holder.
- When connecting the cable, assure a sufficient length so that the operation of retinal camera is not limited.
- The cable holder position is adjustable with the quantity of cables.

#### **How to adjust**

Remove the tilting cover (1 lower screw). Loosen the screw of the cable holder for adjusting.

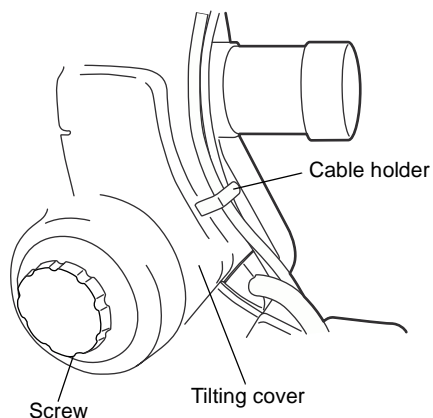

• How to take a picture

- 1 Set the **UPPER/LOWER SELECTOR SWITCH** to "UPPER" on the control panel.
- 2 Perform alignment and photography for retina in the same procedure as "COLOR PHOTOGRAPHY", "FAG PHOTOGRAPHY" or "ICG FLUORESCEIN PHOTOGRAPHY".

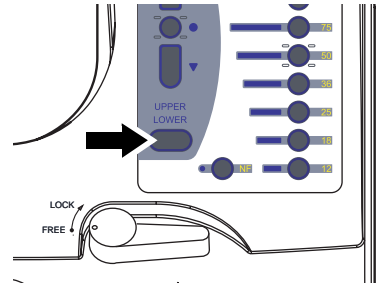

Press the **PHOTOGRAPHY SWITCH** on the joystick, and the retinal image is recorded in the image recorder.



Set the shutter speed to "1/30 sec." for the F mount single-lens reflex digital camera (a product in the market).

TV relay lens list

Model	Type of photography (*1)			Mount			Video camera (*2)			Size (mm) WxDxH
	1PORT	2PORT	3PORT	1PORT	2PORT	3PORT	1PORT	2PORT	3PORT	
TL-207	C, G, F			F			F			85x124x234
TL-208	C, G, F			Bayonet			B			85x145x238
TL-209	F, G, (I), A			C			D			85x140x236
TL-210D	C	G, F, (I), A		Bayonet	C		B	D		85x173x238
TL-211	C, G, F			F			F			85x123x228
TL-230T	C	G, F, I, A	I	Bayonet	C	C	B	D	A	85x226x255
TL-231	I			C			A			85x161x246
TL-232D	C, G, F	I		Bayonet	C		B	A		85x185x238
TL-233D	I	G, F, I, A		C	C		A	D		85x173x246
TL-234D	C, G, F, I	I		C	C		C	A		85x185x234
TL-235T	C	G, F, I, A	I	F	C	C	F	D	A	85x226x255
TL-236D	C, G, F	I		F	C		F	A		85x198x228

(\*1)

C	COLOR
G	GREEN (RED FREE)
F	FAG
I	ICG
A	AUTO FLUO

(\*2)

A	1/2 C mount single-plate infrared camera
B	1/2 three-plate bayonet mount
C	1/2 C mount three-plate type
D	2/3 C mount single-plate type
F	F mount single-lens reflex digital camera

Consult your dealer for the camera.

One electronic photography device can be connected.

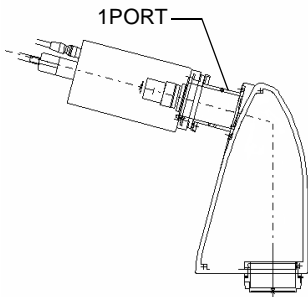

Two electronic photography devices can be connected.

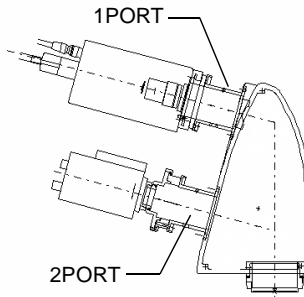

Three electronic photography devices can be connected.

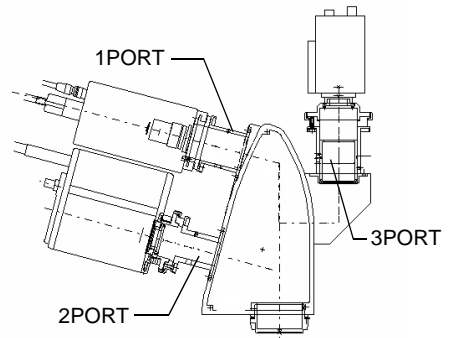







# REFERENCE MATERIAL

## SHAPE OF PLUG

Country	Voltage/frequency	Shape of plug
Mexico	110V/50Hz	Type C&E
Argentina	220V/60Hz	Type A
Peru	220V/60Hz	Type A
Venezuela	110V/50Hz	Type C&E
Bolivia & Paraguay	220V/60Hz	Type A (Most common) Type H (Infrequently)
Chile	220V/60Hz	Type A
Colombia	110V/50Hz	Type C
Brazil	220V/60Hz 127V/60Hz	Type A Type C
Ecuador	110V/50Hz	Type C&E
USA	120V/60Hz	Type A (Hospital Grade)
Canada	120V/60Hz	Type A (Hospital Grade)

## SYMBOL

Symbol	IEC Publication	Description	Description (French)
	60417-5032	Alternating current	Courant alternatif
	60348	Attention, consult accompanying documents	Attention, consulter les documents d'accompagnement
	60417-5008	Off (power: disconnection from the mains)	Éteint (courant: coupure avec le secteur)
	60417-5007	On (power: connection of the mains)	Allumé (courant: raccordement sur le secteur)
	60878-02-02	Type B applied part	Partie appliquée du Type B

## **USABLE AUTOMATIC INSTRUMENT TABLE**

### **Automatic instrument table AIT-15S**

Because the instrument height can be adjusted to the desired position, you can take a picture more easily.

#### Specifications

- Dimensions .....510(W) × 490(D) mm
- Table height.....600 ~ 820mm
- Table size .....490 × 500mm
- Weight.....Approx. 23kg (only the instrument body)
- Power consumption .....270VA
- Maximum loadage.....50kg

## **ELECTROMAGNETIC COMPATIBILITY**

This product conforms to the EMC standard (IEC 60601-1-2 : 2001).

- a) MEDICAL ELECTRICAL EQUIPMENT needs special precautions regarding EMC and needs to be installed and put into service according to the EMC information provided in the ACCOMPANYING DOCUMENTS.
- b) Portable and mobile RF communications equipment can affect MEDICAL ELECTRICAL EQUIPMENT.
- c) The use of ACCESSORIES, transducers and cables other than those specified, with the exception of transducers and cables sold by the manufacturer of the EQUIPMENT or SYSTEM as replacement parts for internal components, may result in increased EMISSIONS or decreased IMMUNITY of the EQUIPMENT or SYSTEM.
- d) The EQUIPMENT or SYSTEM should not be used adjacent to or stacked with other equipment. If adjacent or stacked use is necessary, the EQUIPMENT or SYSTEM should be observed to verify normal operation in the configuration in which it will be used.
- e) The use of the ACCESSORY, transducer or cable with EQUIPMENT and SYSTEMS other than those specified may result in increased EMISSION or decreased IMMUNITY of the EQUIPMENT or SYSTEM.

Item	Article code	Model No.	Length (m)
CBL_D1X-TRC-D15	445104200	—	5.0
CABLE_VS200-D2	445102300	—	1.0
CBL_D1X-TRC-VS2	445105200	—	5.0

<b>Guidance and manufacturer's declaration - electromagnetic emissions</b>		
The TRC-50DX is intended for use in the electromagnetic environment specified below. The customer or the user of the TRC-50DX should assure that it is used in such an environment.		
<b>Emissions test</b>	<b>Compliance</b>	<b>Electromagnetic environment - guidance</b>
RF emissions CISPR 11	Group 1	The TRC-50DX uses RF energy only for its internal function. Therefore, its RF emissions are very low and are not likely to cause any interference in nearby electronic equipment.
RF emissions CISPR 11	Class B	The TRC-50DX is suitable for use in all establishments, including domestic establishments and those directly connected to the public low-voltage power supply network that supplies buildings used for domestic purposes.
Harmonic emissions IEC61000-3-2	Class A	
Voltage fluctuations/ flicker emissions IEC61000-3-3	Complies	

**Guidance and manufacturer's declaration - electromagnetic immunity**

The TRC-50DX is intended for use in the electromagnetic environment specified below. The customer or the user of the TRC-50DX should assure that it is used in such an environment.

<b>Immunity test</b>	<b>IEC 60601 test level</b>	<b>Compliance level</b>	<b>Electromagnetic environment - guidance</b>
Electrostatic discharge (ESD) IEC 61000-4-2	± 6 kV contact ± 8 kV air	± 6 kV contact ± 8 kV air	Floors should be wood, concrete or ceramic tile. If floors are covered with synthetic material, the relative humidity should be at least 30%.
Electrical fast transient/burst IEC 61000-4-4	± 2 kV for power supply lines ± 1 kV for input/output lines	± 2 kV for power supply lines ± 1 kV for input/output lines	Mains power quality should be that of a typical commercial or hospital environment.
Surge IEC 61000-4-5	± 1 kV differential mode ± 2 kV common mode	± 1 kV differential mode ± 2 kV common mode	Mains power quality should be that of a typical commercial or hospital environment.
Voltage dips, short interruptions and Voltage variations on power supply input lines IEC 61000-4-11	<5% $U_t$ (>95% dip in $U_t$ ) for 0.5 cycle 40% $U_t$ (60% dip in $U_t$ ) for 5 cycles 70% $U_t$ (30% dip in $U_t$ ) for 25 cycles <5% $U_t$ (>95% dip in $U_t$ ) for 5 sec	<5% $U_t$ (>95% dip in $U_t$ ) for 0.5 cycle 40% $U_t$ (60% dip in $U_t$ ) for 5 cycles 70% $U_t$ (30% dip in $U_t$ ) for 25 cycles <5% $U_t$ (>95% dip in $U_t$ ) for 5 sec	Mains power quality should be that of a typical commercial or hospital environment. If the user or the TRC-50DX requires continued operation during power mains interruptions, it is recommended that the TRC-50DX be powered from an uninterruptible power supply or battery.
Power frequency (50/60 Hz) magnetic field IEC 61000-4-8	3 A/m	3 A/m	Power frequency magnetic fields should be at levels characteristic of a typical location in a typical commercial or hospital environment.

NOTE  $U_t$  is the a.c. mains voltage prior to application of the test level.

### Guidance and manufacturer's declaration - electromagnetic immunity

The TRC-50DX is intended for use in the electromagnetic environment specified below. The customer or the user of the TRC-50DX should assure that it is used in such an environment.

Immunity test	IEC 60601 test level	Compliance level	Electromagnetic environment - guidance
Conducted RF IEC 61000-4-6	3 Vrms 150kHz to 80MHz	3 V	Portable and mobile RF communications equipment should be used no closer to any part of the TRC-50DX, including cables, than the recommended separation distance calculated from the equation applicable to the frequency of the transmitter.  Recommended separation distance $d = 1.2 \sqrt{P}$
Radiated RF IEC 61000-4-3	3 V/m 80MHz to 2.5GHz	3 V/m	$d = 1.2 \sqrt{P}$ 80MHz to 800MHz $d = 2.3 \sqrt{P}$ 800MHz to 2.5GHz  where $P$ is the maximum output power rating of the transmitter in watts (W) according to the transmitter manufacturer and $d$ is the recommended separation distance in meters (m).  Field strengths from fixed RF transmitters, as determined by an electromagnetic site survey, <sup>a</sup> should be less than the compliance level in each frequency range. <sup>b</sup>  Interference may occur in the vicinity of equipment marked with the following symbol:  

NOTE 1 At 80 MHz and 800 MHz, the higher frequency range applies.

NOTE 2 These guidelines may not apply in all situations. Electromagnetic propagation is affected by absorption and reflection from structures, objects and people.

a Field strengths from fixed transmitters, such as base stations for radio (cellular/cordless) telephones and land mobile radios, amateur radio, AM and FM radio broadcast and TV broadcast cannot be predicted theoretically with accuracy. To assess the electromagnetic environment due to fixed RF transmitters, an electromagnetic site survey should be considered. If the measured field strength in the location in which the TRC-50DX is used exceeds the applicable RF compliance level above, the TRC-50DX should be observed to verify normal operation. If abnormal performance is observed, additional measures may be necessary, such as reorienting or relocating the TRC-50DX.

b Over the frequency range 150 kHz to 80 MHz, field strengths should be less than 3 V/m.

**Recommended separation distance between  
portable and mobile RF communications equipment and the TRC-50DX**

The TRC-50DX is intended for use in an electromagnetic environment in which radiated RF disturbances are controlled. The customer or the user of the TRC-50DX can help prevent electromagnetic interference by maintaining a minimum distance between portable and mobile RF communications equipment (transmitters) and the TRC-50DX as recommended below, according to the maximum output power of the communications equipment.

Rated maximum output power of transmitter W	Separation distance according to frequency of transmitter m		
	150kHz to 80MHz $d = 1.2 \sqrt{P}$	80MHz to 800MHz $d = 1.2 \sqrt{P}$	800MHz to 2.5GHz $d = 2.3 \sqrt{P}$
0.01	0.12	0.12	0.23
0.1	0.38	0.38	0.73
1	1.2	1.2	2.3
10	3.8	3.8	7.3
100	12	12	23

For transmitters rated at a maximum output power not listed above, the recommended separation distance  $d$  in metres (m) can be estimated using the equation applicable to the frequency of the transmitter, where  $P$  is the maximum output power rating of the transmitter in watts (W) according to the transmitter manufacturer.

NOTE 1 At 80 MHz and 800 MHz, the separation distance for the higher frequency range applies.

NOTE 2 These guidelines may not apply in all situations. Electromagnetic propagation is affected by absorption and reflection from structures, objects and people.

# RELATION BETWEEN SETTING OF ILLUMINATION/ FLASH LEVEL AND MAXIMUM RADIANCE

When the maximum radiance is "1", the ratio of radiance is shown below in setting of illumination/flash level.

Illumination level (Observation light)

Indicated set value	Level ratio
0	0.00
1	0.02
2	0.03
3	0.04
4	0.06
5	0.10
6	0.15
7	0.20
8	0.25
9	0.35
10	0.50
11	0.70
12	1.00

Flash level (Photographing light)

Indicated set value	Level ratio
9	0.03
12	0.04
18	0.06
21	0.07
25	0.08
30	0.10
36	0.12
43	0.14
50	0.17
62	0.21
75	0.25
86	0.29
100	0.33
125	0.42
150	0.50
175	0.58
200	0.67
250	0.83
300	1.00

Ratio of maximum level in photography conditions

Conditions	Level ratio
Color photography 20°, SMALL PUPIL	1.00
Color photography 20°	0.65
Color photography 35°/50°, SMALL PUPIL	0.56
Color photography 35°/50°	0.36
FAG photography, SMALL PUPIL	0.04
FAG photography	0.03

Refer to P.33 for setting the illumination level indication, and P.24 for setting the flash level indication.

# INFORMATION ABOUT THE OPTICAL RADIATION HAZARD FOR THE USER

## Relative spectral output of this instrument

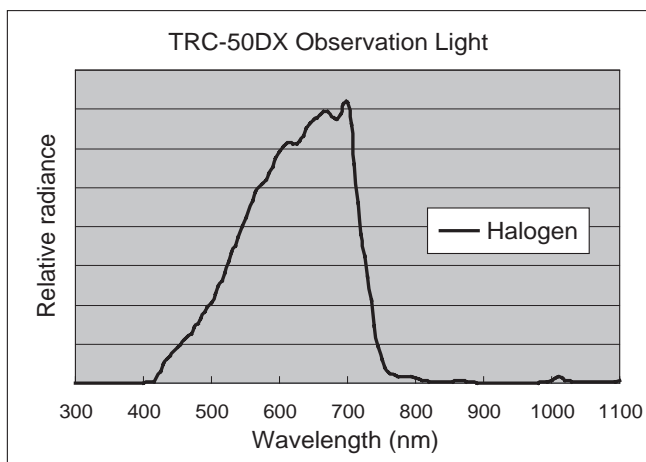

## Photochemical light source radiance of this instrument

LA (without crystalline lens) : 6.4 mW/(cm<sup>2</sup>·sr)

LB (with crystalline lens) : 6.2 mW/(cm<sup>2</sup>·sr)

### Meaning of LA and LB

- Spectrally weighted photochemical radiances LB and LA give a measurement of the potential that exists for a beam of light to cause photochemical hazard to the retina. LB gives the measurement for eyes in which the crystalline lens is in place. LA gives this measurement either for eyes in which the crystalline lens has been removed (aphakes) and has not been replaced by a UV-blocking lens or for eyes of very young children.
- The value stated for TRC-50DX gives a measurement of hazard potential when the instrument is operated at maximum intensity and maximum aperture. Values of LB or LA over 80mW/(cm<sup>2</sup>·sr) are considered high for beams which wholly fill a dilated pupil.
- Because prolonged intense light exposure can damage the retina, the use of the device for ocular examination should not be unnecessarily prolonged, and the brightness setting should not exceed what is needed to provide clear visualization of the target structures. This device should be used with filter that eliminate UV radiation (<400 nm) and, whenever possible, filters that eliminate short-wavelength blue light (<420 nm).
- The retinal exposure dose for a photochemical hazard is a product of the radiance and the exposure time. If the value of radiance were reduced in half, twice the time would be needed to reach the maximum exposure limit.
- While no acute optical radiation hazards have been identified for fundus cameras, it is recommended that the intensity of light directed into the patient's eye be limited to the minimum level which is necessary for diagnosis. Infants, aphakes and persons with diseased eyes will be at greater risk. The risk may also be increased if the person being examined has had any exposure with the same instrument or any other ophthalmic instruments using a visible light source during the previous 24 hours. This will apply particularly if the eye has been exposed to retinal photography.



---

Please provide the following information when contacting us regarding questions about this instrument:

- Model name: TRC-50DX
- Serial No.: This is described on the rating nameplate on the right side of the power supply unit.
- Period of use: Please inform us of the date of purchase.
- Defective condition: Please provide us with as much detail as possible on the problem.

---

RETINAL CAMERA TRC-50DX

INSTRUCTION MANUAL  
2006 version (2006.07-50TH①)  
Date of issue: Aug. 1st, 2006

Published by TOPCON CORPORATION

75-1 Hasunuma-cho, Itabashi-ku, Tokyo, 174-8580 Japan.

---

**TOPCON MEDICAL SYSTEMS, INC**

37 West Century Road, Paramus, New Jersey 07652, U.S.A. Phone: 201-261-9450 Fax: 201-387-2710 www.topcon.com

**TOPCON CANADA INC.**

110 Provencher Avenue, Boisbriand, QC J7G 1N1 CANADA Phone: 450-430-7771 Fax: 450-430-6457 www.topcon.ca

**TOPCON EUROPE B.V.**

(European Representative)

Essebaan 11, 2908 LJ Capelle a/d IJssel, THE NETHERLANDS Phone: 010-4585077 Fax: 010-4585045 www.topcon.eu

**TOPCON EUROPE MEDICAL B.V.**

(European Sole Sales Company)

Essebaan 11, 2908 LJ Capelle a/d IJssel, THE NETHERLANDS Phone: 010-4585077 Fax: 010-2844940 www.topcon.eu

ITALY OFFICE: Via Dell' Industria n.60, 20037 Paderno Dugnano, (Milano), ITALY Phone: 02-61-25-583 E-mail: info.topconitaly@tiscali.it www.topcon.it

**TOPCON DEUTSCHLAND G.m.b.H.**

Giesslerallee 31-33 D-47877 Willich GERMANY Phone: 02154-8850 Fax: 02154-885111 www.topcon.de Med@topcon.de

**TOPCON ESPAÑA S.A.**

HEAD OFFICE: Frederic Mompou 5, ED. Euro 3, 08960, Sant Just Desvern Barcelona, SPAIN Phone: 93-4734057 Fax: 93-4733932 www.topconesp.com

MADRID OFFICE: Avenida Burgos, 16E, 1° 28036, Madrid, SPAIN Phone: 91-302-4129 Fax: 91-383-3890

**TOPCON S.A.R.L.**

89, rue de Paris 92585 Clichy, Cedex, FRANCE Phone: 01-4106-9494 Fax: 01-4739-0251

**TOPCON SCANDINAVIA A.B.**

Neongatan 2 S-43151 Mölndal, SWEDEN Phone: 031-7109200 Fax: 031-7109249 info@topcon.se

**TOPCON (GREAT BRITAIN) LTD.**

Topcon House, Kennet Side, Bone Lane, Newbury, Berkshire RG14 5PX United Kingdom Phone: 01635-551120 Fax: 01635-551170

**TOPCON SOUTH ASIA PTE.LTD.**

Blk 192 Pandan Loop, #07-01 Pantech Industrial Complex, SINGAPORE 128381 Phone: 62780222 Fax: 62733540 www.topcon.com.sg

**TOPCON INSTRUMENTS (MALAYSIA) SDN.BHD.**

Excella Business Park Block C, 1st Floor, Jalan Ampang Putra, Taman Ampang Hillir, 55100 Kuala Lumpur, MALAYSIA Phone: 03-42701192 Fax: 03-42704508

**TOPCON INSTRUMENTS (THAILAND) CO.,LTD.**

77/162 Sinn Sathorn Tower, 37th Fl., Krungdhonburi Rd., Klongtongsai, Klongsarn, Bangkok 10600, THAILAND Phone: 440-1152-7 Fax: 440-1158

**TOPCON KOREA CORPORATION**

2F Yooseoung Bldg., 1595-3, Seocho-Dong, Seocho-Gu, Seoul, 137-876 KOREA Phone: 02-2055-0321 Fax: 02-2055-0319 www.topcon.co.kr

**TOPCON OPTICAL (H.K.) LTD.**

2/F., Meeco Industrial Bldg., No.53-55 Au Pui Wan Street, Fo Tan Road, Shatin, N.T., Hong Kong Phone: 2690-1328 Fax: 2690-2221 E-mail: sales@topcon.com.hk

**TOPCON CORPORATION BEIJING OFFICE**

Block No.9, Kangding Street Beijing Economic-Technological Development Area, Beijing, 100176, CHINA Phone: 10-6780-2799 Fax: 10-6780-2790

**TOPCON CORPORATION BEIRUT OFFICE**

P.O.Box 70-1002 Antelias, BEIRUT-LEBANON Phone: 961-4-523525/523526 Fax: 961-4-521119

**TOPCON CORPORATION DUBAI OFFICE**

C/O Atlas Medical FZCO., P.O.Box 54304 C-25, Dubai Airport Free Zone, UAE Phone: 971-4-2995900 Fax: 971-4-2995901

---

**TOPCON CORPORATION**

75-1 Hasunuma-cho, Itabashi-ku, Tokyo, 174-8580 Japan.

Phone: 3-3558-2520 Fax: 3-3960-4214 www.topcon.co.jp