

INSTRUCTION MANUAL
AUTO CHART PROJECTOR

ACP-8

INTRODUCTION

Thank you for purchasing the TOPCON ACP-8 Auto Chart Projector.

(To get the best use this instrument, please carefully read these instructions and keep this Instruction Manual in a convenient location for future reference.)

This text outlines the ACP-8 Auto Chart Projector and describes basic operations, troubleshooting, checking, maintenance and cleaning.

To encourage the safe, efficient use of this instrument and to prevent danger to the operator and others, we suggest you carefully read the "Displays for Safe Use" and the "Safety Cautions".

Again, please keep this Instruction Manual in a convenient location for future reference.

Precautions



- This machine is a precision instrument; install it in a place that is set to the following conditions: temperature (10~40°C), humidity (30~85%) and atmospheric pressure (70~106KPa). Avoid direct exposure to sunlight.
 - To ensure smooth operation, install the instrument on a level surface free of vibrations. Also, do not place any objects on the instrument.
 - Before using the instrument, connect all cables properly.
 - Use the specified source voltage. ($\pm 10\%$ 50/60Hz ± 1 kHz)
 - When not in use, turn the power off and dust cover on the instrument.
 - To ensure a correct reading, do not soil the measuring window with finger prints, dust, etc. Also, do not touch the measuring nozzle except when cleaning.
-

DISPLAY FOR SAFE USE



In order to encourage the safe use of this product and prevent any danger to the operator and others or damage to properties, important warnings are placed on the product and inserted in the instruction manual.

We suggest that everyone understand the meaning of the following displays and icons before reading the "Safety Cautions" and text.

WARNING









DISPLAY	MEANING
 WARNING	Ignoring or disregarding this display may lead to death or serious injury.
 CAUTION	Ignoring or disregarding this display may lead to personal injury or physical damage.
<ul style="list-style-type: none">• Injury refers to cuts, bruises, sprains, fractures, burn, electric shock, etc.• Physical damage refers to extensive damage to buildings or equipment and furniture.	

ICONS







ICONS	MEANING
	This indicates Prohibition. Specific content is expressed with words or an icon either inserted in the icon itself or located next to the icon.
	This indicates Mandatory Action. Specific content is expressed with words or an icon either inserted in the icon itself or located next to the icon.
	This icon indicates Hazard Alerting (Warning). Prohibition. Specific content is expressed with words or an icon either inserted in the icon itself or located next to the icon.

SAFETY CAUTIONS

WARNING

Icons	Prevention item	Page
	Do not break down, modify or repair the equipment. Doing so can cause electric shock. Request a repair from your dealer.	20
	To prevent an electric shock hazard, do not allow water or other foreign matter to enter into the instrument.	--
	To avoid fire and electric shock in the case of tumbling, do not place a cup or vessel containing water/fluid on the instrument.	--
	To avoid electric shock, do not insert objects or metals through the vent holes or gaps or place them inside the machine body.	--
	Connect the power plug to a three-prong properly grounded AC socket with an earth. If it is connected to a socket that is not grounded, it can cause a fire and electric shock due to leakage.	11
	Unplug the power cable before removing the fuse cover to replace the fuse. Removing the fuse cover with the power cable plugged in can cause electric shock. Do not install the power cord on the body with the fuse cover removed.	25
	Use only attached fuses (For 100, 120V range: T-1.6A, 250V For 220, 230, 240V range: T-1A, 250V). Using other fuses may cause a fire in the event that the instrument fails.	25
	Should any anomaly, such as smoke, occur, immediately switch OFF the power source and unplug the power cable. Continued use while ignoring the condition may cause a fire. Contact your dealer for repair.	--

 CAUTION

Icons	Prevention item	Page
	Do not tilt the device or place it in an unstable place. Otherwise, the device may topple over, drop or cause injury.	11
	Handling the power plug with wet hands can cause electric shock.	11
	To avoid electric shock, unplug the power cable when replacing the projection lamp.	23
	Do not replace the projection lamp immediately after turning off the light. Otherwise, you might get burnt by the hot temperature of the lamp.	23
	When this instrument is not used for a long time, remove the batteries from the remote controller.	11
	<p>This instrument has been tested (with 120V/230V) and found to comply with IEC60601-1-2: 1993.</p> <p>This instrument radiates radio frequency energy within standard and may affect other devices in vicinity.</p> <p>If you have found out by turning on/off the instrument that it affects other devices, it is recommended to change the direction, keep a proper distance against other devices or change the outlet.</p> <p>If you have a question, consult with the selling agent.</p>	--

USAGE AND MAINTENANCE

PURPOSE

This Auto Chart Projector "ACP-8" is a precision electrical device for medical use that must be used under the instruction of a doctor.

FUNCTION AND INTENDED APPLICATION

This product is designed to project the eye test chart for visual acuity examination to the screen. In order to control the eye test chart, controller is available.

USER MAINTENANCE

To maintain the safety and performance of the equipment, never attempt to do maintenance on your own. Ask our service personnel for repairs except for the items specified here which can be maintained by the user. For details, follow the instructions.

FUSE REPLACEMENT

The primary fuses for the main body may be replaced by a non-trained service technician. For details, refer to "Replacing the Fuse" on page 25.

LAMP REPLACEMENT

The projection lamp can be replaced. Refer to the instructions in "Replacing the Projection Lamp" on page 23 for details.

ESCAPE CLAUSE

- TOPCON shall not take any responsibility for damage due to fire, earthquakes, actions by a third party or other accidents, or the negligence and misuse of the user and use under unusual conditions.
- TOPCON shall not take any responsibility for damage derived from the inability to use this equipment, such as a loss of business profit and suspension of business.
- TOPCON shall not take any responsibility for damage caused by operations other than those described in this Instruction Manual.
- Diagnoses shall be made on the responsibility of pertaining doctors and TOPCON shall not take any responsibility for the results of such diagnoses.

WARNING INDICATIONS AND POSITIONS

To ensure the safe usage of this equipment, precaution indications are provided. Abide by the following warning instructions. If any of the following labels are missing, please contact us at the address printed on the back cover of this manual.

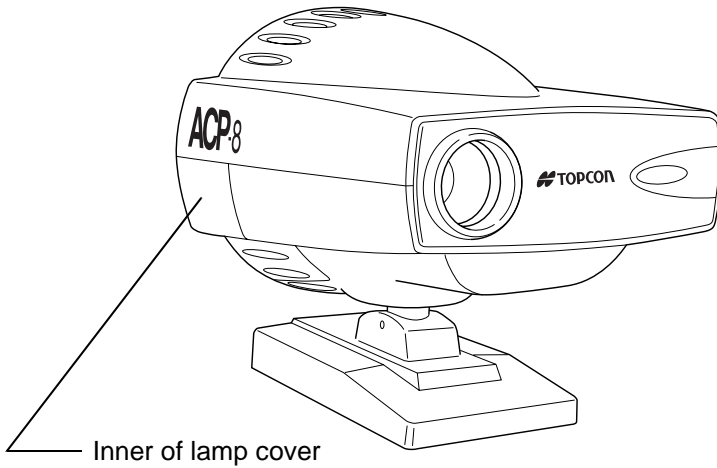

⚠ CAUTION
Disconnect the power cable. Wait until the lamp is completely cool before removing.
Débranchez le câble d'alimentation. Attendez que l'ampoule soit complètement refroidie avant de l'enlever.

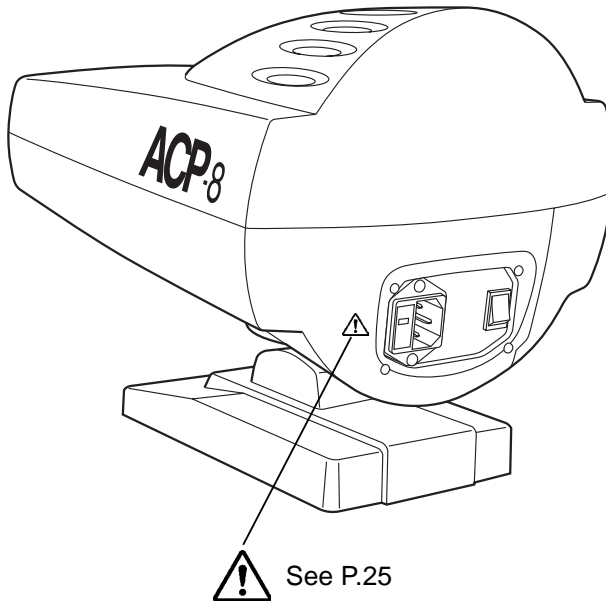

CONTENT

INTRODUCTION	1
DISPLAY FOR SAFE USE	2
SAFETY CAUTIONS	3
USAGE AND MAINTENANCE	5
ESCAPE CLAUSE	5
WARNING INDICATIONS AND POSITIONS	6

Names of parts

Names of parts on the main body	8
Remote controller	9
Standard accessories	10

Operation procedures

Preparations	11
--------------------	----

Usage guide

Operating the random access controller	15
Using the program functions	16
Using charts for measuring binocular visual functions	18

Troubleshooting

Operating procedures for troubleshooting	20
--	----

Chart

.....	21
-------	----

Care and check

Daily Maintenance	23
Changing the channel setting of the remote controller	26
Maintenance	28

Reference

Optional Accessories	29
Specifications	29

Names of parts

Names of parts on the main body

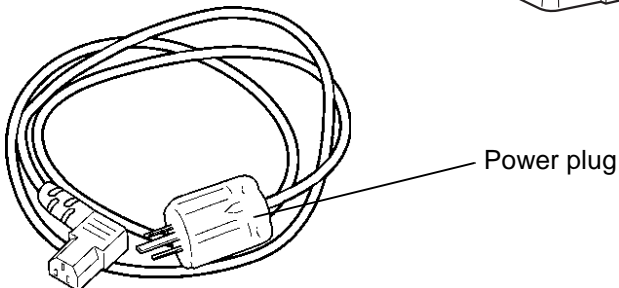
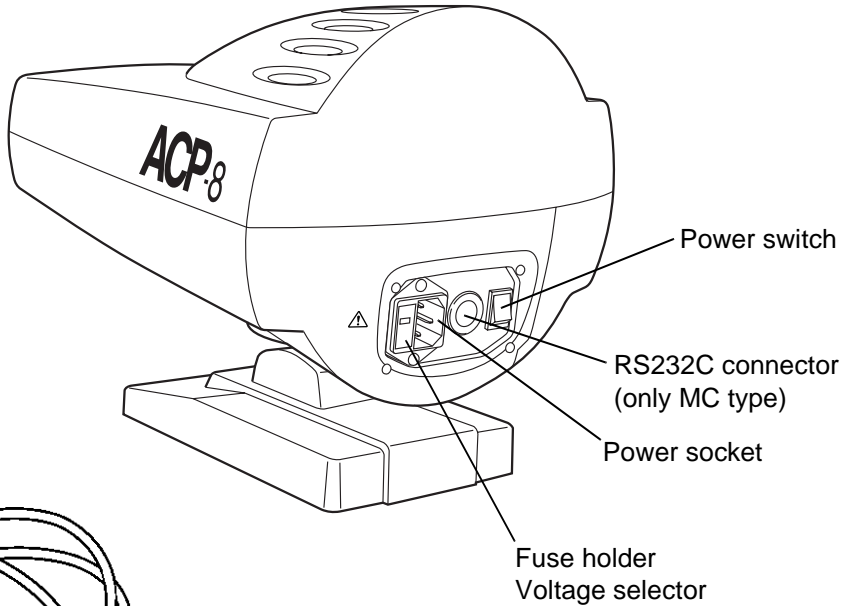
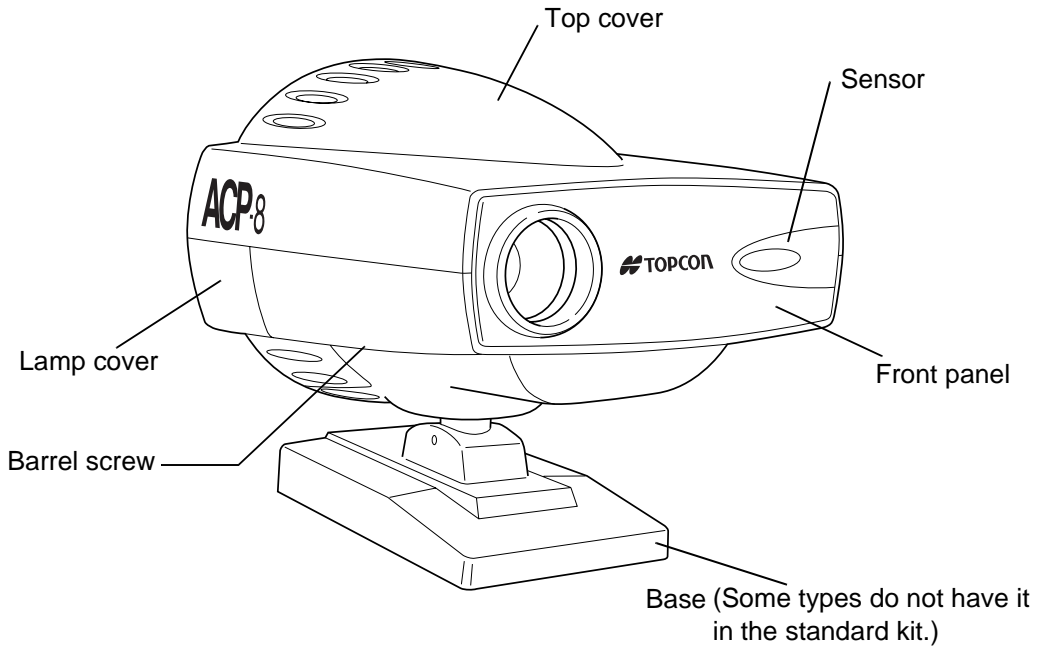

Remote controller



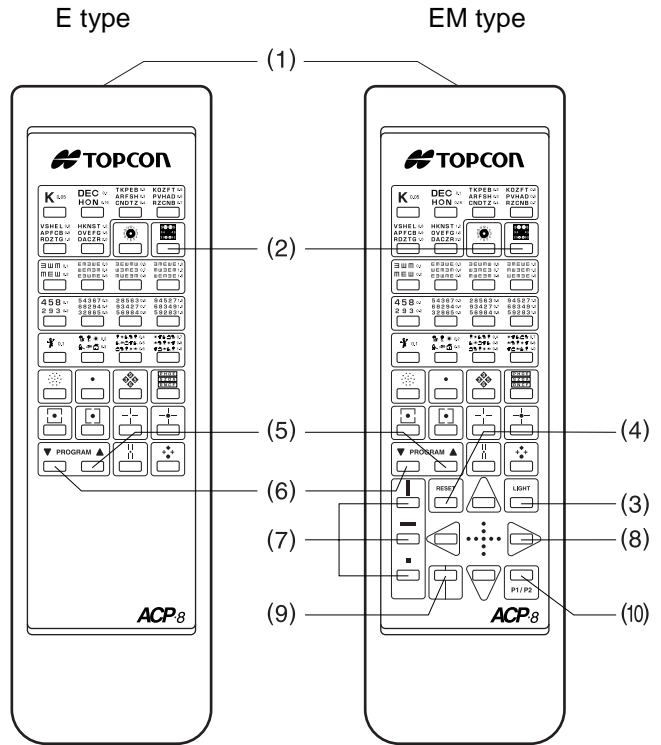

- 1 Light emitter
 - 2 Chart switch
 - 3 Light switch
 - 4 Reset switch (*)
 - 5 Forward switch (*)
 - 6 Back switch (*)
 - 7 Mask selector
 - 8 Mask transfer switch
 - 9 R&G switch
 - 10 Program switch
- * These switches are used when activating the 'program' mode.



(Example : A type chart)

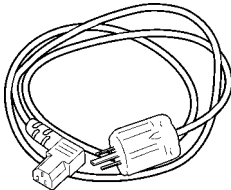
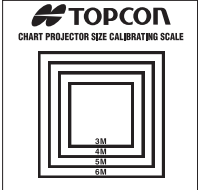
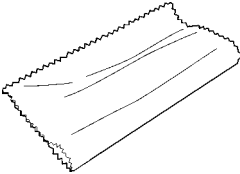
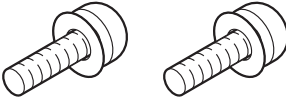

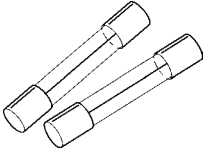
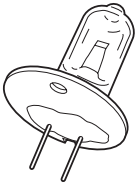
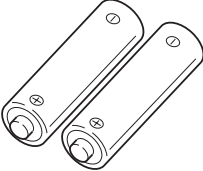
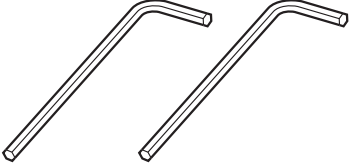
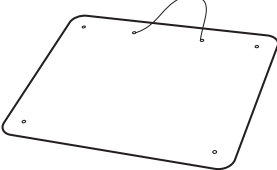

Standard accessories

The following are the standard accessories. Please check if they are all included.() refers to the number of items.

<p>Power cord (1)</p> 	<p>Calibration card (1)</p> 
<p>Silicone cloth (1)</p> 	<p>Attachment screws (2) Not included in the types without base.</p> 
<p>Dust cover (1)</p> 	<p>Spare fuse (2)</p> 
<p>Spare lamp (1)</p> 	<p>Dry battery (UM-3) (2)</p> 
<p>Hexagonal wrench for focus adjustment (2)</p> 	<p>Screen (1)</p> 
<p>Instruction manual (1)</p> 	

Operation procedures

Preparations

 Caution	Do not tilt the device or place it in an unstable place. Otherwise, the device may topple over, drop or cause injury.
 Warning	Connect the power plug to a three-prong properly grounded AC socket with an earth. If it is connected to a socket that is not grounded, it can cause a fire and electric shock due to leakage.
 Caution	Handling the power plug with wet hands can cause electric shock.
 Caution	When this instrument is not used for a long time, remove the batteries from the remote controller.

- 1** Place the instrument at the same level as the person to be measured. When installing by using the base, insert the shaft of the instrument into the base as illustrated. (This method is same when using the stand or wall mount.)

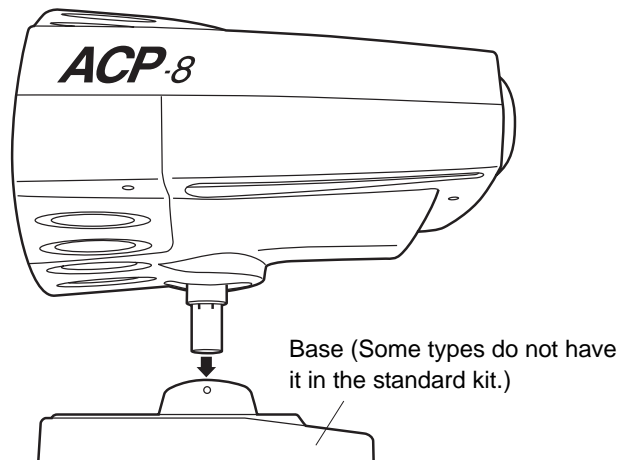

- 2** Turn the power switch 'off'.
 - 3** When more than two instruments are installed in close proximity to each other, it is necessary to set the channel by the DIP switches of the body and the signal channel switches of the remote controller in order to avoid interference. (Up to four instruments may be installed at the same location)
- * At the time of shipment, the instrument is set at channel 1.
 - * To change the channel, see "Changing the channel setting of the remote controller" on page 26.

- 4** Insert the connector of the power cord into the power socket on the body and insert the power supply plug into the outlet.

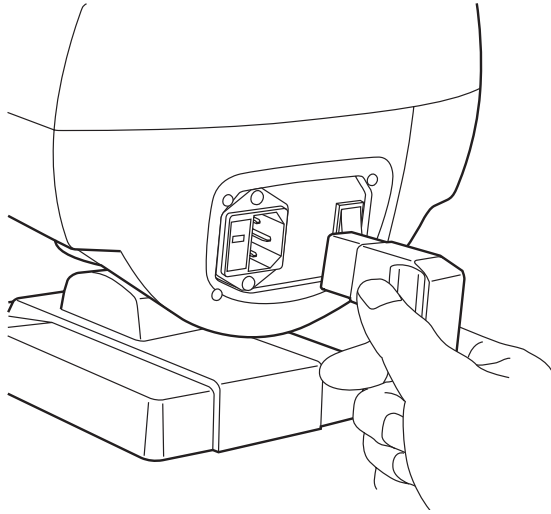

- 5** Turn the power switch 'on'.

- 6** Remove the battery cover from the back of the remote controller.

- 7** Insert the dry batteries into the remote controller as illustrated and replace the battery cover.

(How to insert batteries)

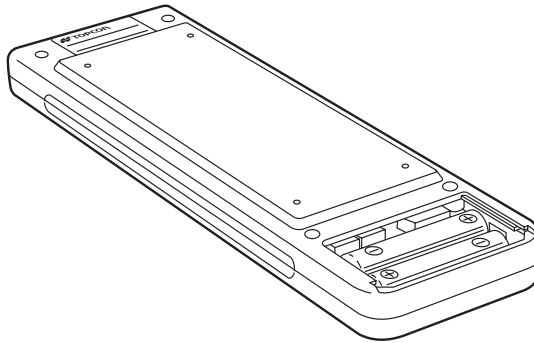

- 8** Adjust the position of the body so that the projected light is centered on the screen.

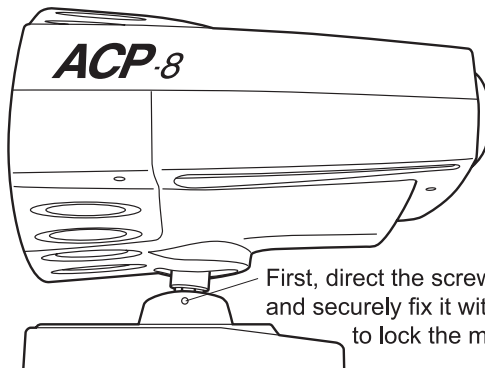

First, direct the screw to the screen board and securely fix it with the hexagonal wrench to lock the main body.

For E, EM, MC type

- 9** Loosen the barrel screw about a half of a turn with the attached hexagonal wrench.

Move the knob in the arrow direction so that the projection on the screen is sharp and clear. For proper calibration, the projection of the chart which has 0.1 (or 20/200) visual acuity should contact the inner side of one of the scales on the calibration card which corresponds to the desired refracting distance.

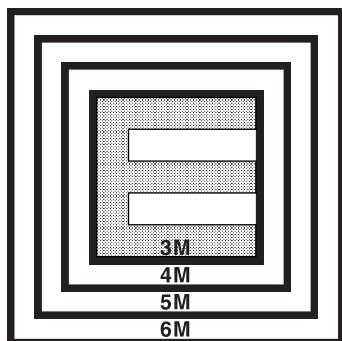
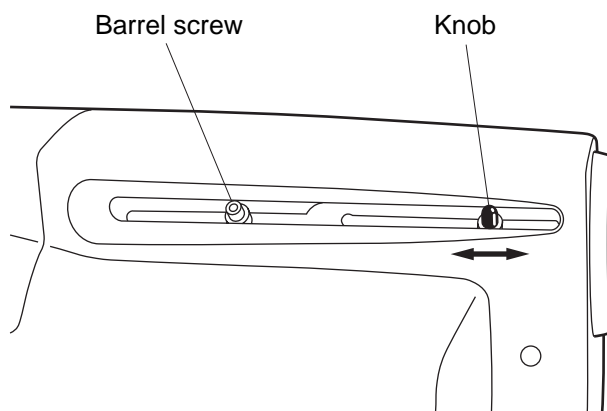

- 10** If the size does not match the respective refracting distance scale, move the instrument either toward or away from the screen and then repeat items 9 above.
- 11** Fix the barrel screw to complete preparation.

For R type (variable focus lens type)

- 12** Loosen the first lens-barrel screw and the second lens-barrel screw about a half of a turn.

Move the lens-barrel screw in the arrow direction with the hexagonal wrench inserted.

The first lens-barrel screw: size

The second lens-barrel screw: focus

Move the first lens-barrel screw to roughly fit the size and move the second lens-barrel screw to achieve the focus.

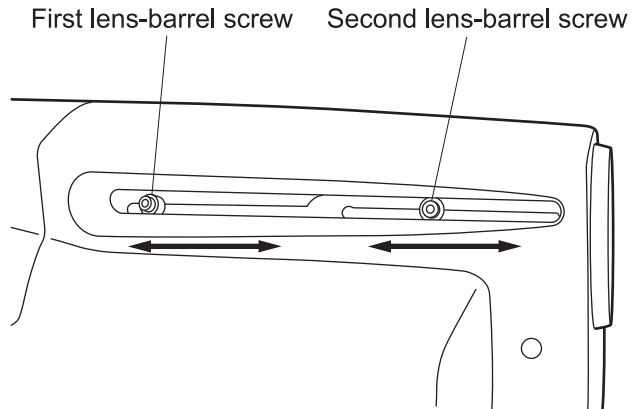

- 13** Move the first and second lens-barrel screw forward and/or backward to focus 20/200 (or 0.1) visual acuity "E" on to the projection screen. Place the calibration card on the projection screen. The "E" of the 20/200 slide should fill and just touch the inner sides of the scale which corresponds to the desired refracting distance.

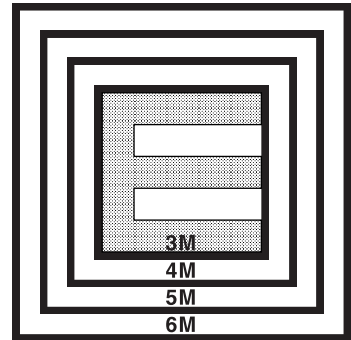

- * The variable focus lenses permits the R type to be positioned at the following projection distances relative to refracting distance:

Refracting Distance	Projection Distance
3m	2.90 to 3.70m
4m	3.80 to 4.80m
5m	4.70 to 5.90m
6.1m	5.70 to 7.10m

For example:

At a refracting distance of 5 meters, the R type Auto Chart Projector can be positioned at a distance of 4.70 to 5.90 meters. Within this range, the variable focus objective lenses can project the properly calibrated image.

- 14** Fix the barrel screw to complete preparation.

Usage guide

Operating the random access controller

- 1** Turn the power switch on. The chart will be reset to the start position and the lamp will light up.
- 2** Direct the light emitter on the remote controller to the sensor on the projector body or use a wall with high reflectivity to receive the reflected light on the light emitter and press each switch before using.

- Switch functions

- (1) Chart switchProjects the chart as indicated on the switch.
 - (2) Light switchTurns the lamp on/off.
 - (3) Reset switch.Returns to the step 1 chart in the program.
 - (4) Forward switch.Automatically advances the step in the program.
 - (5) Back switchAutomatically backs the step in the program.
 - (6) Mask selector.Allows selection of a mask that is appropriate for the chart. (horizontal mask, vertical mask, one character mask).
 - (7) Mask transfer switchMoves the mask in the direction as indicated on the switch. When the mask moves to the maximum (minimum) indication of a chart being projected, the next (previous) chart in the sequence will automatically appear. Charts can be switched within the same type of charts.
 - (8) R&G filter switchR&G filter can be applied only for the chart that allows R&G filtering.
 - (9) Switch the program P1 with the program P2.
- * See P.16 for using the program function.
 - * When the lamp is turned off, the lamp will light up by pressing either the (1) or (3)-(9) switches.
 - * When the mask is not open, it will automatically be open by pressing the (1) chart switch.
 - * When the instrument is not used for 10 minutes, it will be automatically turned off (Auto shut-off mechanism)

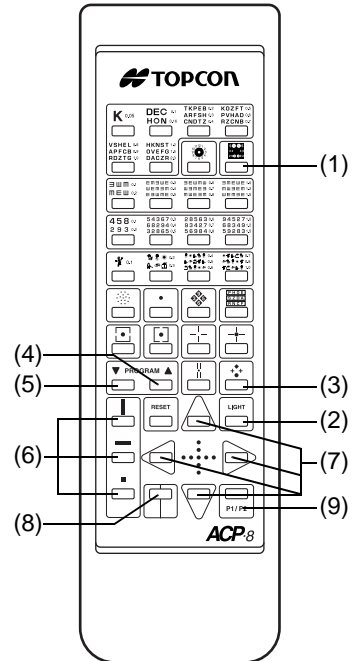

Example: A type chart

Using the program functions

1 How to program the measuring procedure

(1) To start programming

Turn the power switch on while pressing the reset switch. Release the reset switch when the buzzer sounds once. The chart will return to the start position, the lamp lights up and the buzzer sounds twice. Select either program 1 or 2 by pressing P1 or P2. (Buzzer once: P1 initial value, buzzer twice: P2). Press the “^” switch. The buzzer sounds three times.

(2) Programming the charts

Press the chart switch or the mask switch according to the measuring procedure to project and press the “^” switch. The buzzer sounds four times and this completes one step.

* Repeat this to program the procedure. Programming is available for up to 30 steps.

(3) Completing the programming

Press the reset switch. This completes the programming.

* Programming 30 steps will automatically complete the function without pressing the reset switch.

* Turning the power switch off won't erase the program.





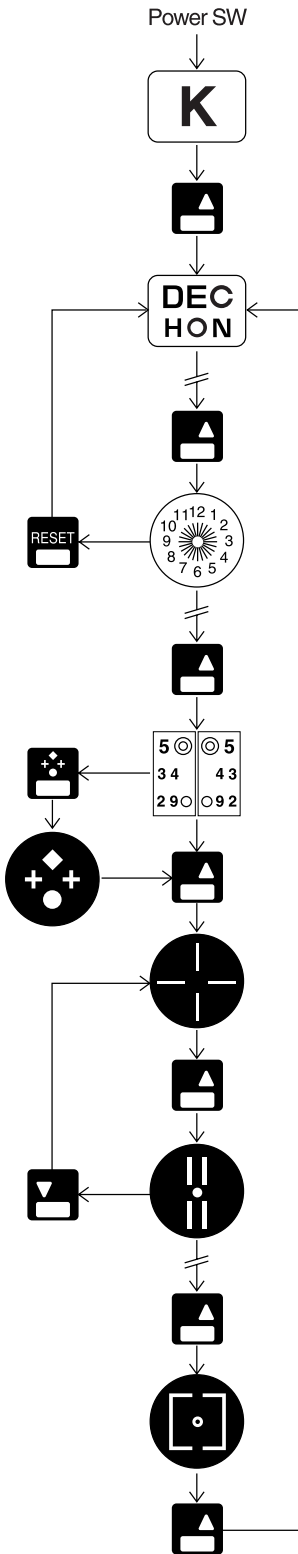





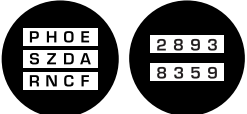
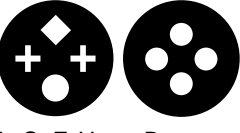

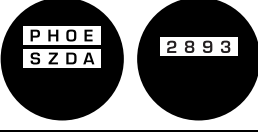
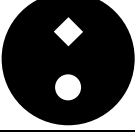
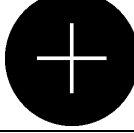

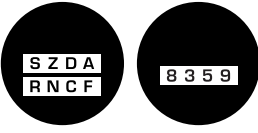
* Follow the steps above to start a new program. The former program will be erased to start a new program.







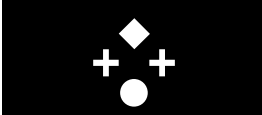
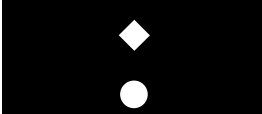
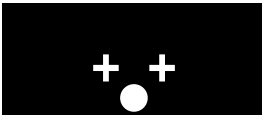
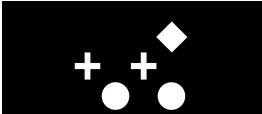

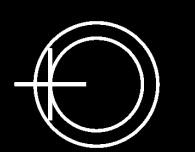
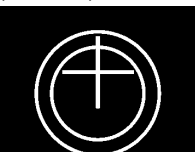
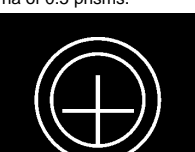

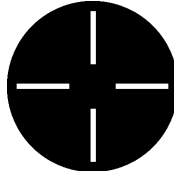

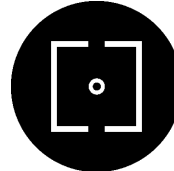
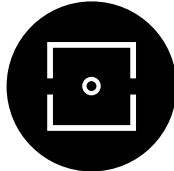
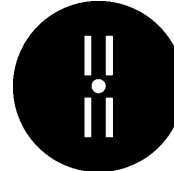
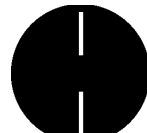
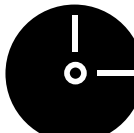
2 Carrying out program-base examinations (Example : A type chart)

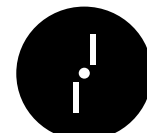
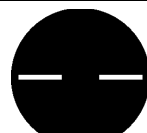
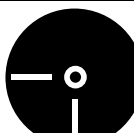

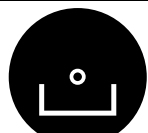
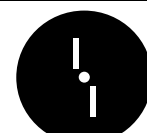
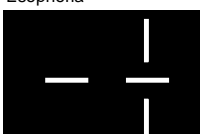
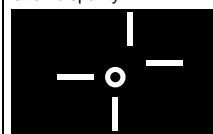
- Turn the power switch on.
- The chart at the start position will be projected.
- Step 1 chart will be called up.
- Step 1 chart will be projected.
- You can reset to the beginning (step 1) of the program-based examination during an examination.
- Any desired chart can be projected during the course of a program-based examination.
- Pressing the program up and down switches can back up the program at any time. The program can be backed up as many steps as necessary.
- The chart of the last step will be projected.
- The instrument will return to the first (step 1) chart in the program-based examination.

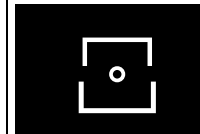
Using charts for measuring binocular visual functions

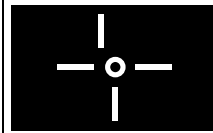
		Polarized R and G test	Binocular balance test	Worth four dot test	Cross ring test
Chart		 A, C, F type	 A, B, *F, *H C type	 A, C, F, H B type	
Filter		Polarizing filters	Polarizing filters	Red filter for the right eye and green filter for the left eye	Red filter for the right eye and green filter for the left eye
Purpose		Test of binocular refraction and accommodation balance	Test of the final binocular refraction balance	Test of the function of binocular fusion	Test of the presence and level of latent heterophoria
How the charts are viewed	Right eye				
	Left eye				
	How the charts are seen binocularly	<p>The right eye is over corrected and the left eye is under corrected.</p>  <p>The left eye is over corrected and the right eye is under corrected.</p>  <p>The binocular refraction and accommodation balance are achieved when the two reds or two greens are seen at the same intensity.</p> 	<p>There is a variance of degree between the right eye and the left eye.</p>  <p>Adjust the spherical power to provide binocular balance.</p>  <p>*The Characters used in the F and H types are not the same as those shown above.</p>	<p>In the case where 4 dots are seen, there will be normal fusion. The white (bottom) color indicates which eye can see better. If red is seen mixed with green, the right and left eyes function at the same level.</p>  <p>If only two targets are seen, the left eye is suppressed.</p>  <p>If only three green targets are seen, the right eye is suppressed.</p>  <p>If five targets are seen, it indicates that the patient has diplopia.</p> 	<p>Indicates exophoria of 3 prisms.</p>  <p>Indicates esophoria of 2 prisms.</p>  <p>Indicates left eye hyperphoria of 1 prisms.</p>  <p>Indicates left hypophoria of 0.5 prisms.</p> 

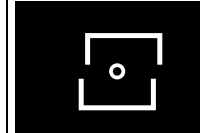
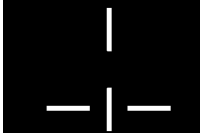
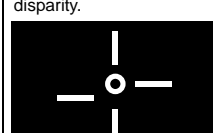
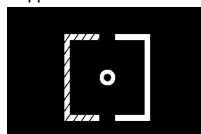
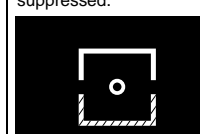
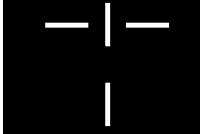
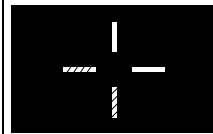
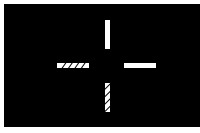
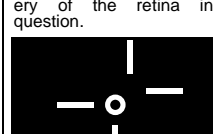
Polarized crosshair test	Reticle heterophobia test with a fixation target	Coincidence test	Coincidence test	Stereo test
 A, B, C, F, H type	 A, F, H type	 A, B, C, F, H type	 A, C, F type	 A, B, C, F, H type
Polarizing filters	Polarizing filters	Polarizing filters	Polarizing filters	Polarizing filters
Test of the accommodation balance and heterophobia	Heterophobia which can not be examined by the reticle testing is tested.	Test of aniseikonia and vertical heterophobia which can not be examined by polarized crosshair test.	Test of aniseikonia and vertical heterophobia which can not be examined by polarized crosshair test.	Test the presence of stereoscopy.
				
				
Esophoria	The right eye has an infixation disparity.	Aniseikonia of about 7% (equivalent to two lines) A single line indicates about 3.5%.	Aniseikonia of about 7% (equivalent to two lines) A single line indicates about 3.5%.	Two lines are seen in fusion to form a single line image and floated or sunk against the central circle. The binocula parallaxes is about 13 minutes and the lower line is seen floating about 1.1m (when seen at a distance of 5m with a PD of 64mm)
				The binocula parallaxes is about 13 minutes and the lower line is seen floating about 1.1m (when seen at a distance of 5m with a PD of 64mm)
Exophoria	Indicates that the right eye has an infrafixation disparity.	Vertical heterophoria	Vertical heterophoria	If the axis of the polarizing filter is reversed at the same time for both eyes and seen sunk about 2.1m, it is normal.
				If the images are slowly fused, there is still correctable heterophoria.
Left eye hyperphoria	Indicates that the right eye has an suprafixation disparity.	If either line is seen thinner, the eye in question is suppressed.	If either line is seen thinner, the eye in question is suppressed.	Verify with another heterophoria test. If it takes some time until the image appears to float, the patient may have an exophoria.
				If it takes some time until the image sinks, the patient may have an esophoria.
Left eye hypophoria	Left eye hypophoria			
				
If either line is seen thinner, the eye in question is suppressed.	If either is clearly visible, there is observed suppression of the periphery of the retina in question.			
				

Troubleshooting

Operating procedures for troubleshooting

Operating procedures for troubleshooting

 Warning	<p>Do not break down, modify or repair the equipment. Doing so can cause electric shock. Request a repair from your dealer.</p>
--	---

Check the items in the following check list when you experience a problem. When the situation is not recovered by the indicated action or the problem does not comply with the description in the "Situation" column in the check list, contact your dealer or the address on the back cover of this manual.

Check list

Situation	Example	Action	Reference page
The projection lamp does not light with the power switch on.	• Is the power supply plug connected to the incoming line source?	Plug it securely in the outlet.	--
	• Is the power cord connected?	Plug it securely in the power on the main body.	11
	• Is the fuse blown?	See P.25 for fuse replacement.	25
	• Is the lamp burnt out?	See P.23 for lamp replacement.	23
The instrument does not function when the remote controller switch is pressed.	• Are the batteries fresh?	Replace the battery.	11
	• Is there anything interrupting the light emitter on the remote controller and the sensor on the body?	Remove the interrupting object.	--
	• Is the remote controller set at the proper channel setting with the body?	See P.26 for adjusting the channel.	26

When you can't resolve the problem after checking all the items described above, contact us at the address shown on the back cover of this instruction manual.

Chart

Optotypes

A Type...EUROPE

1. Letter's chart : 0.05
2. Letter's chart : 0.1, 0.16
3. Letter's chart : 0.2, 0.3, 0.4
4. Fixed astigmatic sunburst
5. Letter's chart : 0.5, 0.6, 0.7
6. Letter's chart : 0.8, 0.9, 1.0
7. Letter's chart : 1.2, 1.5, 2.0
8. R and G chart
9. Cross cylinder dots
10. Balance Chart : 0.5, 0.6, 0.8, 1.0
11. Polarized R and G chart
12. Coincidence test
13. Coincidence test
14. Fixation spot
15. Polarized crosshair
16. Polarized crosshair
17. Stereo test
18. worth four dot test
19. Children's chart : 0.1
20. Children's chart : 0.2, 0.3
21. Children's chart : 0.4, 0.5, 0.6
22. Children's chart : 0.7, 0.8, 1.0
23. Numbers chart : 0.1, 0.2
24. Numbers chart : 0.3, 0.4, 0.5
25. Numbers chart : 0.6, 0.7, 0.8
26. Numbers chart : 1.0, 1.2, 1.5
27. Illiterate E's chart : 0.1, 0.2
28. Illiterate E's chart : 0.3, 0.4, 0.5
29. Illiterate E's chart : 0.6, 0.7, 0.8
30. Illiterate E's chart : 1.0, 1.2, 1.5

C Type...GERMANY

1. Letter's chart : 0.05
2. Letter's chart : 0.1, 0.16
3. Fixed astigmatic sunburst
4. Letter's chart : 0.2, 0.3, 0.4
5. Letter's chart : 0.5, 0.6, 0.7
6. Letter's chart : 0.8, 0.9, 1.0
7. Letter's chart : 1.2, 1.5, 2.0
8. R and G chart
9. Cross ring
10. Balance Chart : 0.5, 0.6, 0.8, 1.0
11. Polarized R and G chart
12. Coincidence test
13. Coincidence test
14. Polarized crosshair
15. Stereo test

B (B1) Type...SINGAPORE, OTHERS

1. Letter's chart : 20/400
2. Letter's chart : 20/300
3. Letter's chart : 20/200, 20/150
4. Letter's chart : 20/100, 20/80
5. Letter's chart : 20/70, 20/60, 20/50
6. Letter's chart : 20/40, 20/30, 20/25
7. Letter's chart : 20/20, 20/15, 20/10
8. Fixed astigmatic sunburst
9. Cross cylinder dots
10. Letter's chart : 20/20
11. Illiterate E's chart : 20/200, 20/100
12. Illiterate E's chart : 20/80, 20/70, 20/60
13. Illiterate E's chart : 20/50, 20/40, 20/30
14. Illiterate E's chart : 20/25, 20/20, 20/15
15. R and G chart : 20/50, 20/40, 20/30
16. R and G chart : 20/25, 20/20, 20/15
17. Balance Chart : 20/80, 20/60, 20/50, 20/40
18. Balance Chart : 20/30, 20/25, 20/20, 20/15
19. Polarized crosshair
20. Stereo test
21. Coincidence test (B1 : Fixation spot)
22. Worth four dot test
23. Children's chart : 20/200
24. Children's chart : 20/100, 20/80
25. Children's chart : 20/60, 20/40, 20/30
26. Numbers chart : 20/200, 20/150
27. Numbers chart : 20/100, 20/80, 20/70
28. Numbers chart : 20/60, 20/50, 20/40
29. Numbers chart : 20/30, 20/25, 20/20
30. R and G chart

16. Worth four dot test
17. Children's chart : 0.1
18. Children's chart : 0.2, 0.3
19. Children's chart : 0.4, 0.5, 0.6
20. Children's chart : 0.7, 0.8, 1.0
21. Landolt rings : 0.2
22. Landolt rings : 0.25
23. Landolt rings : 0.3
24. Landolt rings : 0.4
25. Landolt rings : 0.5
26. Landolt rings : 0.63
27. Landolt rings : 0.7
28. Landolt rings : 0.8
29. Landolt rings : 1.0
30. Landolt rings : 1.25

F Type...OTHERS

1. Landolt rings : 0.05
2. Landolt rings : 0.1, 0.16
3. Landolt rings : 0.2, 0.3, 0.4
4. Fixed astigmatic sunburst
5. Landolt rings : 0.5, 0.6, 0.7
6. Landolt rings : 0.8, 0.9, 1.0
7. Landolt rings : 1.2, 1.5, 2.0
8. R and G chart
9. Cross cylinder dots
10. Balance Chart : 0.5, 0.6, 0.8, 1.0
11. Polarized R and G chart
12. Coincidence test
13. Coincidence test
14. Fixation spot
15. Polarized crosshair
16. Polarized crosshair
17. Stereo test
18. Worth four dot test
19. Children's chart : 0.2, 0.3
20. Children's chart : 0.4, 0.5, 0.6
21. Children's chart : 0.7, 0.8, 1.0
22. Numbers chart : 0.1, 0.2
23. Numbers chart : 0.3, 0.4, 0.5
24. Numbers chart : 0.6, 0.7, 0.8
25. Numbers chart : 1.0, 1.2, 1.5
26. Illiterate E's chart: 0.1, 0.16
27. Illiterate E's chart: 0.2, 0.3, 0.4
28. Illiterate E's chart: 0.5, 0.6, 0.7
29. Illiterate E's chart: 0.8, 0.9, 1.0
30. Illiterate E's chart: 1.2, 1.5, 2.0

H Type...U.S.A.

1. Letter's chart : 20/400
2. Letter's chart : 20/200, 20/150
3. Letter's chart : 20/100, 20/80
4. Letter's chart : 20/70, 20/60, 20/50
5. Letter's chart : 20/40, 20/30, 20/25
6. Letter's chart : 20/20, 20/15, 20/10
7. Fixed astigmatic sunburst
8. Cross cylinder dots
9. Letter's chart : 20/20, 20/20, 20/20
10. Letter's chart : 20/25, 20/20(Number), 20/15
11. Illiterate E's chart: 20/100, 20/80
12. Illiterate E's chart: 20/70, 20/60, 20/50
13. Illiterate E's chart: 20/40, 20/30, 20/25
14. Illiterate E's chart: 20/20, 20/20, 20/15
15. R & G chart
16. Balance chart
17. Polarized crosshair
18. Polarized crosshair
19. Stereo test
20. Fixation spot
21. Coincidence test
22. Worth four dot test
23. Children's chart : 20/100
24. Children's chart : 20/80, 20/80
25. Children's chart : 20/40, 20/30, 20/20
26. Number's chart : 20/200, 20/150
27. Number's chart : 20/100, 20/80
28. Number's chart : 20/70, 20/60, 20/50
29. Number's chart : 20/40, 20/30, 20/25
30. Number's chart : 20/20, 20/15, 20/10

Care and check

Daily Maintenance

- This instrument is very sensitive to dust. Protect the instrument with the dust cover when it is not in use.
- Turn the power switch off when the instrument is not used.

Replacing the Projection Lamp



Caution

To avoid electric shock, unplug the power cable when replacing the projection lamp.



Caution

Do not replace the projection lamp immediately after turning off the light. Otherwise, you might get burnt by the hot temperature of the lamp.

- 1** Turn power switch 'off'.
- 2** Remove the lamp cover screw and remove the cover.

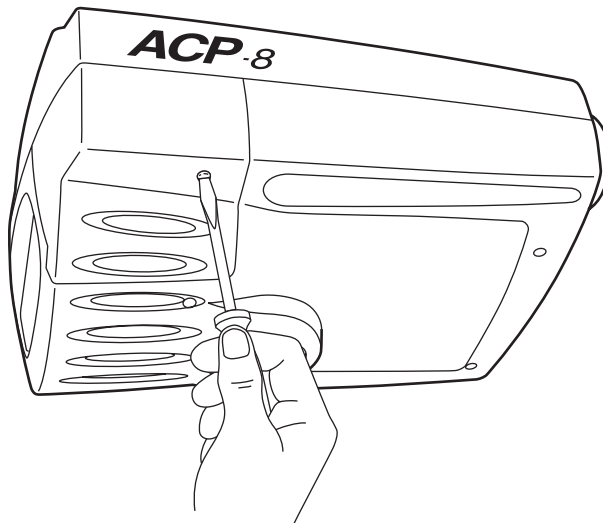

- 3** Remove the lamp attaching screws, hold the socket and remove the lamp.

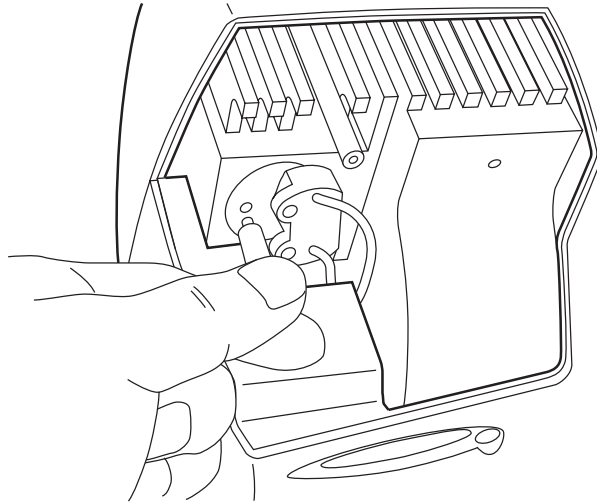

- 4** Hold the socket and the lamp flange and remove the lamp from the socket.

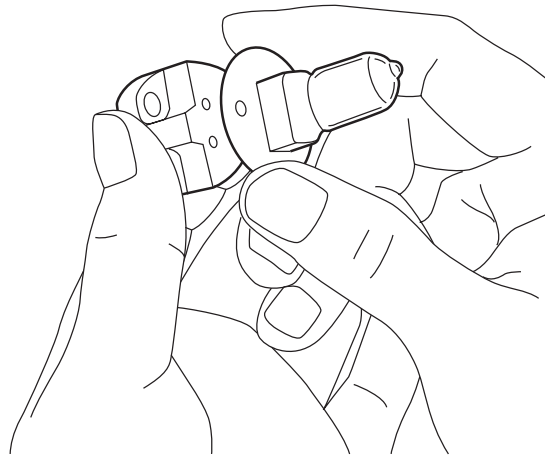

- 5** Install the spare lamp securely as shown in the diagram. Make sure that you install it in the correct direction. (see diagram)

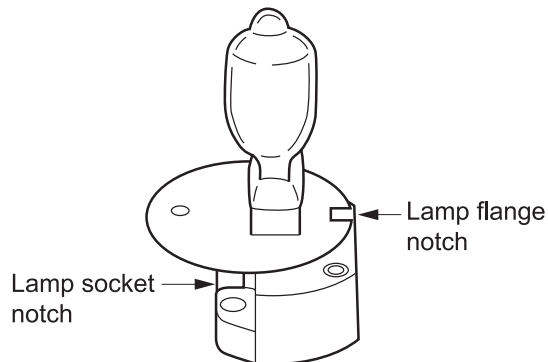

(Note) Do not touch the glass tube of the lamp directly with your finger. In case you touch the glass tube by accident, wipe the fingerprints off with alcohol.

- 6** Match the protruded part of the lamp attaching area with the lamp flange notch and tighten them with the lamp attaching screw to secure the lamp
- 7** Place the lamp cover on.
- 8** Turn the power switch 'on'.
- 9** Make a trial projection to check that there is no illumination irregularity. If there is any irregularity, turn the power off again and check that the lamp is installed properly.

Replacing the Fuse



Warning

Unplug the power cable before removing the fuse cover to replace the fuse. Removing the fuse cover with the power cable plugged in can cause electric shock. Do not install the power cord on the body with the fuse cover removed.



Warning

Use only attached fuses (For 100, 120V range: T-1.6A, 250V For 220, 230, 240V range: T-1A, 250V). Using other fuses may cause a fire in the event that the instrument fails.

- 1** Turn the power switch 'off' and disconnect the power supply plug.
- 2** Simultaneously squeeze both sides of the fuse holder and then remove the fuse holder. The fuses will be removed together with the holder.

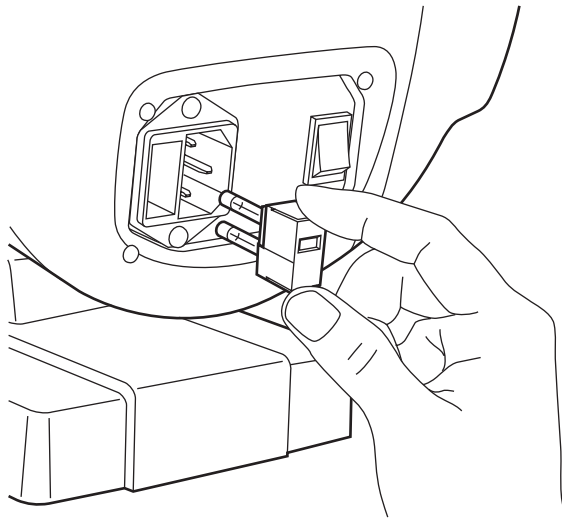

- 3** Remove the blown fuses and insert the spare fuses on the cap of the fuse holder and install it as before (Press to install it). Use the attached fuses or the fuses specified below.

Ordering consumable items

- Contact your dealer or the address on the back cover with the product name, product code and quantity to order consumable items listed below.

Product name	Part code	Maker and type
Lamp	42412 2040	_____
For 100, 120V range: T-1.6A, 250V	05141 1162	Bel Fuse, Part No.5TT(P) 1.6
For 220, 230, 240V range: T-1A, 250V	05141 1013	Bel Fuse, Part No.5TT(P) 1

(Secondary fuse Fuse 1: 125V, 5A-T Fuse 2: 125V, 4A-T)

Changing the channel setting of the remote controller

- 1** Turn the power switch 'off' and unplug the power cable.
- 2** Remove the lamp cover screws and the screws on the lower cover (four in total) and lift the top cover to remove it.
- 3** Change the DIP switch 5 and 6 according to the diagram on page 27.
- 4** Remove the battery cover from the back of the remote controller and change the channel switch S1 and S2. (see diagram)

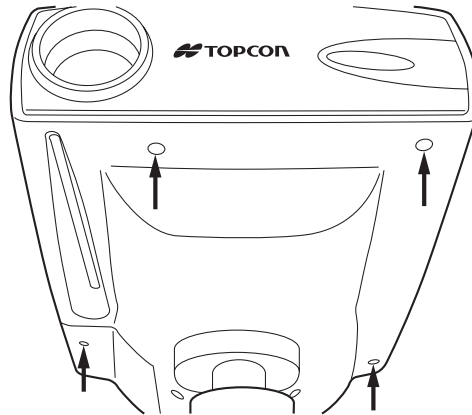

DIP switch position on the main body

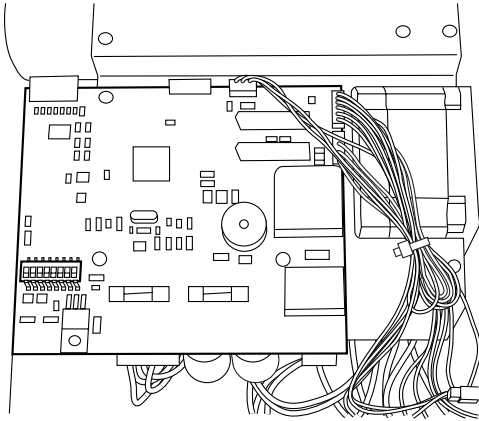

Enlarged view of the DIP switch on the main body

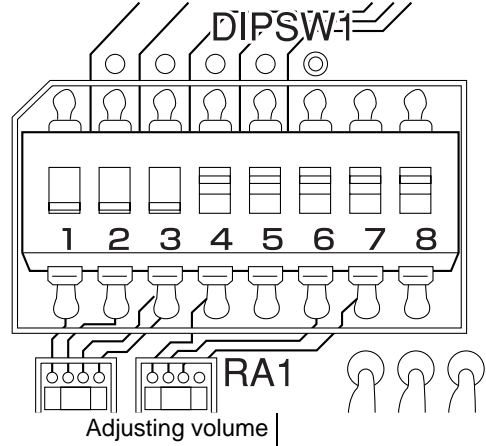

Channel switch position on the remote controller

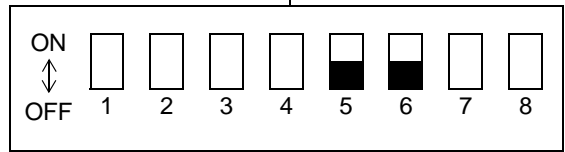
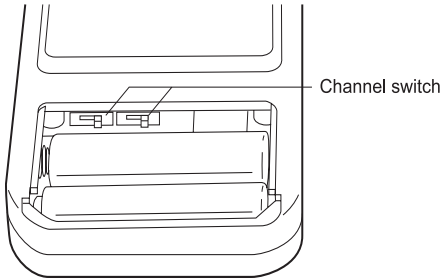

- Switch 1
 - Switch 2
 - Switch 3
 - Switch 4
 - Switch 5
 - Switch 6
 - Switch 7
 - Switch 8
- Plant switch (Switches 1-4)
- Remote control channel change-over (Switches 5-6)
- Plant switch (Switches 7-8)

Channel	Remote control		Body	
			5	6
1	S1=H	S2=H	OFF	OFF
2	S1=L	S2=H	ON	OFF
3	S1=H	S2=L	OFF	ON
4	S1=L	S2=L	ON	ON

5 Replace the top cover after completing the DIP switch setting, tighten the three screws on the lower cover (with the lamp cover removed) and then tighten the lamp cover with attaching screw

Maintenance

Cleaning the cover

Request	Do not wipe the plastic area on the body with a volatile solvent. Wiping the area with thinner, ether, gasoline etc. can cause the color to change and the quality to deteriorate.
----------------	--

- 1** Wipe the cover and the operating panel with a dry cloth when they get dirty.
- 2** When the cover is very dirty, reduce a neutral detergent for dish washing with hot water, dampen a cloth with the mixtur wring the water out, and wipe off the dirt.



When the lens is dirty, wipe it lightly with a dry soft cloth.

Reference

Optional Accessories

- 1** Wall Mount
If the instrument cannot be placed on a table or on the ophthalmic unit, it can be mounted on a wall with the optional wall mount.
- 2** Variable Focus Lens (for ACP-8 MC /8 E /8 EM)
Variable focus lens is utilized when the ACP-8 MC /8 E /8 EM can not be located beside the patient.







Specifications

Refracting distance	2.9 to 6.1m																																		
Projection distance Model ACP-8/8 E/8 MC/8 EM Model ACP-8 R	2.9 to 6.1m 2.9 to 7.1m																																		
Projection magnifications	30 × (at 5m refraction)																																		
Projection size	330 × 270mm, φ300mm (at 5m refraction)																																		
Numbers of charts	30																																		
Chart change-over	1 frame / 0.03sec.																																		
Numbers of masks	Open 1, Horizontal line 5, Vertical line 8, Single isolation 21, R and G 1																																		
Mask change-over	1 frame / 0.03sec.																																		
Program step	Max. of 30 steps are available × 2 Type																																		
Model version	<table border="1"> <thead> <tr> <th></th> <th>Masking</th> <th>Programming</th> <th>Variable Focus Lens</th> <th>RS232C</th> <th>Controller</th> </tr> </thead> <tbody> <tr> <td>ACP-8 E</td> <td>-</td> <td>*</td> <td>-</td> <td></td> <td>*</td> </tr> <tr> <td>ACP-8 MC</td> <td>*</td> <td>*</td> <td>-</td> <td>*</td> <td></td> </tr> <tr> <td>ACP-8 EM</td> <td>*</td> <td>*</td> <td>-</td> <td></td> <td>*</td> </tr> <tr> <td>ACP-8 R</td> <td>*</td> <td>*</td> <td>*</td> <td></td> <td>*</td> </tr> </tbody> </table>						Masking	Programming	Variable Focus Lens	RS232C	Controller	ACP-8 E	-	*	-		*	ACP-8 MC	*	*	-	*		ACP-8 EM	*	*	-		*	ACP-8 R	*	*	*		*
	Masking	Programming	Variable Focus Lens	RS232C	Controller																														
ACP-8 E	-	*	-		*																														
ACP-8 MC	*	*	-	*																															
ACP-8 EM	*	*	-		*																														
ACP-8 R	*	*	*		*																														
Tilt range	+/-10° Upward/downward tilt form horizontal line of projection																																		
Projection lamp	12V 50W (Halogen lamp)																																		
Automatic shut-off mechanism	After 10 minutes																																		
Electricity	AC 120, 220, 230 or 240V, 50/60Hz adjustable by voltage selector on the fuse holder																																		
Power consumption	80VA																																		
Dimensions	226 (W) × 300 (D) × 245 (H)																																		
Weight	6.0kgs.																																		

* Conditions during transport or storage temperature: -20~50°C humidity: 10~95%

Shape of plug

Country	Voltage/frequency	Shape of plug
Mexico	110V/50Hz	Type C&E
Argentina	220V/60Hz	Type A
Peru	220V/60Hz	Type A
Venezuela	110V/50Hz	Type C&E
Bolivia & Paraguay	220V/60Hz	Type A (Most common) Type H (Very Little)
Chile	220V/60Hz	Type A
Colombia	110V/50Hz	Type C
Brazil	220V/60Hz 127V/60Hz	Type A Type C
Ecuador	110V/50Hz	Type C&E

Symbol	IEC Publication	Description	Description (French)
	417-5032	Alternating Current	Courant alternatif
	417-5019	Protective earth (ground)	Mise à la terre
	348	Attention, consult accompanying documents	Attention, consulter les documents d'accompagnement
	417-5008	Off (power: disconnection from the mains)	Éteint (courant: coupure avec le secteur)
	417-5007	On (power: connection of the mains)	Allumé (courant: raccordement sur le secteur)
	417-... 878-02-02	Type B applied part	Classe B

Electromagnetic Compatibility

This product conforms to the EMC standard (IEC 60601-1-2 : 2001).

- a) MEDICAL ELECTRICAL EQUIPMENT needs special precautions regarding EMC and needs to be installed and put into service according to the EMC information provided in the ACCOMPANYING DOCUMENTS.
- b) Portable and mobile RF communications equipment can affect MEDICAL ELECTRICAL EQUIPMENT.
- c) The use of ACCESSORIES, transducers and cables other than those specified, with the exception of transducers and cables sold by the manufacturer of the EQUIPMENT or SYSTEM as replacement parts for internal components, may result in increased EMISSIONS or decreased IMMUNITY of the EQUIPMENT or SYSTEM.
- d) The EQUIPMENT or SYSTEM should not be used adjacent to or stacked with other equipment. If adjacent or stacked use is necessary, the EQUIPMENT or SYSTEM should be observed to verify normal operation in the configuration in which it will be used.
- e) The use of the ACCESSORY, transducer or cable with EQUIPMENT and SYSTEMS other than those specified may result in increased EMISSION or decreased IMMUNITY of the EQUIPMENT or SYSTEM.

Item	Article code	Model No.	Length (m)
RS-232C CROSSING CABLE (shielded)	—	—	4.8

Guidance and manufacturer's declaration - electromagnetic emissions

The ACP-8 is intended for use in the electromagnetic environment specified below. The customer or the user of the ACP-8 should assure that it is used in such an environment.

Emissions test	Compliance	Electromagnetic environment - guidance
RF emissions CISPR 11	Group 1	The ACP-8 uses RF energy only for its internal function. Therefore, its RF emissions are very low and are not likely to cause any interference in nearby electronic equipment.
RF emissions CISPR 11	Class B	The ACP-8 is suitable for use in all establishments, including domestic establishments and those directly connected to the public low-voltage power supply network that supplies buildings used for domestic purposes.
Harmonic emissions IEC61000-3-2	Class B	
Voltage fluctuations/ flicker emissions IEC61000-3-3	Complies	

Guidance and manufacturer's declaration - electromagnetic immunity

The ACP-8 is intended for use in the electromagnetic environment specified below. The customer or the user of the ACP-8 should assure that it is used in such an environment.

Immunity test	IEC 60601 test level	Compliance level	Electromagnetic environment - guidance
Electrostatic discharge (ESD) IEC 61000-4-2	± 6 kV contact ± 8 kV air	± 6 kV contact ± 8 kV air	Floors should be wood, concrete or ceramic tile. If floors are covered with synthetic material, the relative humidity should be at least 30%.
Electrical fast transient/burst IEC 61000-4-4	± 2 kV for power supply lines ± 1 kV for input/output lines	± 2 kV for power supply lines ± 1 kV for input/output lines	Mains power quality should be that of a typical commercial or hospital environment.
Surge IEC 61000-4-5	± 1 kV differential mode ± 2 kV common mode	± 1 kV differential mode ± 2 kV common mode	Mains power quality should be that of a typical commercial or hospital environment.
Voltage dips, short interruptions and Voltage variations on power supply input lines IEC 61000-4-11	<5% U_t (>95% dip in U_t) for 0.5 cycle 40% U_t (60% dip in U_t) for 5 cycles 70% U_t (30% dip in U_t) for 25 cycles <5% U_t (>95% dip in U_t) for 5 sec	<5% U_t (>95% dip in U_t) for 0.5 cycle 40% U_t (60% dip in U_t) for 5 cycles 70% U_t (30% dip in U_t) for 25 cycles <5% U_t (>95% dip in U_t) for 5 sec	Mains power quality should be that of a typical commercial or hospital environment. If the user or the ACP-8 requires continued operation during power mains interruptions, it is recommended that the ACP-8 be powered from an uninterruptible power supply or battery.
Power frequency (50/60 Hz) magnetic field IEC 61000-4-8	3 A/m	3 A/m	Power frequency magnetic fields should be at levels characteristic of a typical location in a typical commercial or hospital environment.

NOTE U_t is the a.c. mains voltage prior to application of the test level.

Guidance and manufacturer's declaration - electromagnetic immunity

The ACP-8 is intended for use in the electromagnetic environment specified below. The customer or the user of the ACP-8 should assure that it is used in such an environment.

Immunity test	IEC 60601 test level	Compliance level	Electromagnetic environment - guidance
Conducted RF IEC 61000-4-6	3 Vrms 150kHz to 80MHz	3 V	<p>Portable and mobile RF communications equipment should be used no closer to any part of the ACP-8, including cables, than the recommended separation distance calculated from the equation applicable to the frequency of the transmitter.</p> <p>Recommended separation distance $d = 1.2 \sqrt{P}$</p> <p>$d = 1.2 \sqrt{P}$ 80MHz to 800MHz $d = 2.3 \sqrt{P}$ 800MHz to 2.5GHz</p> <p>where P is the maximum output power rating of the transmitter in watts (W) according to the transmitter manufacturer and d is the recommended separation distance in meters (m).</p> <p>Field strengths from fixed RF transmitters, as determined by an electromagnetic site survey,^a should be less than the compliance level in each frequency range.^b</p> <p>Interference may occur in the vicinity of equipment marked with the following symbol:</p> 
Radiated RF IEC 61000-4-3	3 V/m 80MHz to 2.5GHz	3 V/m	

NOTE 1 At 80 MHz and 800 MHz, the higher frequency range applies.
 NOTE 2 These guidelines may not apply in all situations. Electromagnetic propagation is affected by absorption and reflection from structures, objects and people.

^a Field strengths from fixed transmitters, such as base stations for radio (cellular/cordless) telephones and land mobile radios, amateur radio, AM and FM radio broadcast and TV broadcast cannot be predicted theoretically with accuracy. To assess the electromagnetic environment due to fixed RF transmitters, an electromagnetic site survey should be considered. If the measured field strength in the location in which the ACP-8 is used exceeds the applicable RF compliance level above, the ACP-8 should be observed to verify normal operation. If abnormal performance is observed, additional measures may be necessary, such as reorienting or relocating the ACP-8.

^b Over the frequency range 150 kHz to 80 MHz, field strengths should be less than 3 V/m.

Recommended separation distance between portable and mobile RF communications equipment and the ACP-8

The ACP-8 is intended for use in an electromagnetic environment in which radiated RF disturbances are controlled. The customer or the user of the ACP-8 can help prevent electromagnetic interference by maintaining a minimum distance between portable and mobile RF communications equipment (transmitters) and the ACP-8 as recommended below, according to the maximum output power of the communications equipment.

Rated maximum output power of transmitter W	Separation distance according to frequency of transmitter m		
	150kHz to 80MHz $d = 1.2 \sqrt{P}$	80MHz to 800MHz $d = 1.2 \sqrt{P}$	800MHz to 2,5GHz $d = 2.3 \sqrt{P}$
0.01	0.12	0.12	0.23
0.1	0.38	0.38	0.73
1	1.2	1.2	2.3
10	3.8	3.8	7.3
100	12	12	23

For transmitters rated at a maximum output power not listed above, the recommended separation distance d in metres (m) can be estimated using the equation applicable to the frequency of the transmitter, where P is the maximum output power rating of the transmitter in watts (W) according to the transmitter manufacturer.

NOTE 1 At 80 MHz and 800 MHz, the separation distance for the higher frequency range applies.

NOTE 2 These guidelines may not apply in all situations. Electromagnetic propagation is affected by absorption and reflection from structures, objects and people.

When calling please give us the following information about your unit:

- Machine type: ACP-8
- Manufacturing No. (Shown on the rating plate on the right side of the base.)
- Period of Usage (Please give us the date of purchase).
- Description of Problem (as detailed as possible).

AUTO CHART PROJECTOR ACP-8

INSTRUCTION MANUAL

Version of 2004 (2004.11-200TH②)

Date of issue: 5, November, 2004

Published by TOPCON CORPORATION

75-1 Hasunuma-cho, Itabashi-ku, Tokyo, 174-8580 Japan.

AUTO CHART PROJECTOR

ACP-8

TOPCON MEDICAL SYSTEMS, INC

37 West Century Road, Paramus, New Jersey 07652, U.S.A. Phone: 201-261-9450 Fax: 201-387-2710 www.topcon.com

TOPCON CANADA INC.

110 Provencher Avenue, Boisbriand, QC J7G 1N1 CANADA Phone: 450-430-7771 Fax: 450-430-6457 www.topcon.ca

TOPCON EUROPE B.V.

(European Representative)

Essebaan 11, 2908 LJ Capelle a/d IJssel, THE NETHERLANDS Phone: 010-4585077 Fax: 010-4585045 www.topconeuropa.com

ITALY OFFICE: Via Monfalcone 39, 20092 Cinisello B. mo (MI) ITALY Phone: 02-61-25-583 Fax: 02-61-25-927

TOPCON DEUTSCHLAND G.m.b.H.

Giesslerallee 31-33 D-47877 Willich GERMANY Phone: 02154-8850 Fax: 02154-885111 www.topcon.de Med@topcon.de

TOPCON ESPAÑA S.A.

HEAD OFFICE: Frederic Mompou 5, ED. Euro 3, 08960, Sant Just Desvern Barcelona, SPAIN Phone: 93-4734057 Fax: 93-4733932 www.topconesp.com

MADRID OFFICE: Avenida Burgos, 16E, 1° 28036, Madrid, SPAIN Phone: 91-302-4129 Fax: 91-383-3890

TOPCON S.A.R.L.

89, rue de Paris 92585 Clichy, Cedex, FRANCE Phone: 01-4106-9494 Fax: 01-4739-0251

TOPCON SCANDINAVIA A.B.

Neogatan 2 S-43151 Mölndal, SWEDEN Phone: 031-7109200 Fax: 031-7109249 info@topcon.se

TOPCON (GREAT BRITAIN) LTD.

Topcon House, Kennet Side, Bone Lane, Newbury, Berkshire RG14 5PX United Kingdom Phone: 01635-551120 Fax: 01635-551170

TOPCON SOUTH ASIA PTE.LTD.

Blk 192 Pandan Loop, #07-01 Pantech Industrial Complex, SINGAPORE 128381 Phone: 62780222 Fax: 62733540 www.topcon.com.sg

TOPCON INSTRUMENTS (MALAYSIA) SDN.BHD.

Excella Business Park Block C, 1st Floor, Jalan Ampang Putra, Taman Ampang Hillir, 55100 Kuala Lumpur, MALAYSIA Phone: 03-42701192 Fax: 03-42704508

TOPCON INSTRUMENTS (THAILAND) CO.,LTD.

77/162 Sinn Sathorn Tower, 37th Fl., Krungthongburi Rd., Klontongsai, Klongsarn, Bangkok 10600, THAILAND Phone: 440-1152-7 Fax: 440-1158

TOPCON AUSTRALIA PTY.LTD.

Unit 18, 4 Avenue of Americas Newington NSW 2127 AUSTRALIA Phone: 02-8748-8777 Fax: 02-9647-2926 www.topcon.com.au

TOPCON KOREA CORPORATION

2F Yooseoung Bldg., 1595-3, Seocho-Dong, Seocho-Gu, Seoul, 137-876 KOREA Phone: 02-2055-0321 Fax: 02-2055-0319 www.topcon.co.kr

TOPCON OPTICAL (H.K.) LTD.

2/F., Meeco Industrial Bldg., No. 53-55 Au Pui Wan Street, Fo Tan Road, Shatin, N.T., Hong Kong Phone: 2690-1328 Fax: 2690-2221 E-mail: sales@topcon.com.hk

TOPCON CORPORATION BEIJING OFFICE

1070 Poly Plaza Building, 14 Dongzhimen Nandajie Dongcheng District, Beijing, 100027, CHINA Phone: 10-6501-4191 Fax: 10-6501-4190

TOPCON CORPORATION BEIRUT OFFICE

P.O.Box 70-1002 Antelias, BEIRUT-LEBANON Phone: 961-4-523525/523526 Fax: 961-4-521119

TOPCON CORPORATION DUBAI OFFICE

C/O Atlas Medical FZCO., P.O.Box 54304 C-25, Dubai Airport Free Zone, UAE Phone: 971-4-2995900 Fax: 971-4-2995901

TOPCON CORPORATION

75-1 Hasunuma-cho, Itabashi-ku, Tokyo, 174-8580 Japan.
Phone: 3-3558-2520 Fax: 3-3960-4214 www.topcon.co.jp

4241295992

Printed in Japan 0411-200TH②